



# ACO KerbDrain® BridgeDeck

Combined kerb and drainage for bridges

Product Catalogue



## ACO KerbDrain® BridgeDeck

ACO KerbDrain® BridgeDeck is a versatile combined kerb and drainage solution designed to effectively manage surface water on bridges. The system can be used alone or in combination with other ACO KerbDrain products to create integrated bridge and highway schemes.

### Splayed Moulded Expansion Joint (section view), Splayed 360 Unit and Half Battered 360 Unit

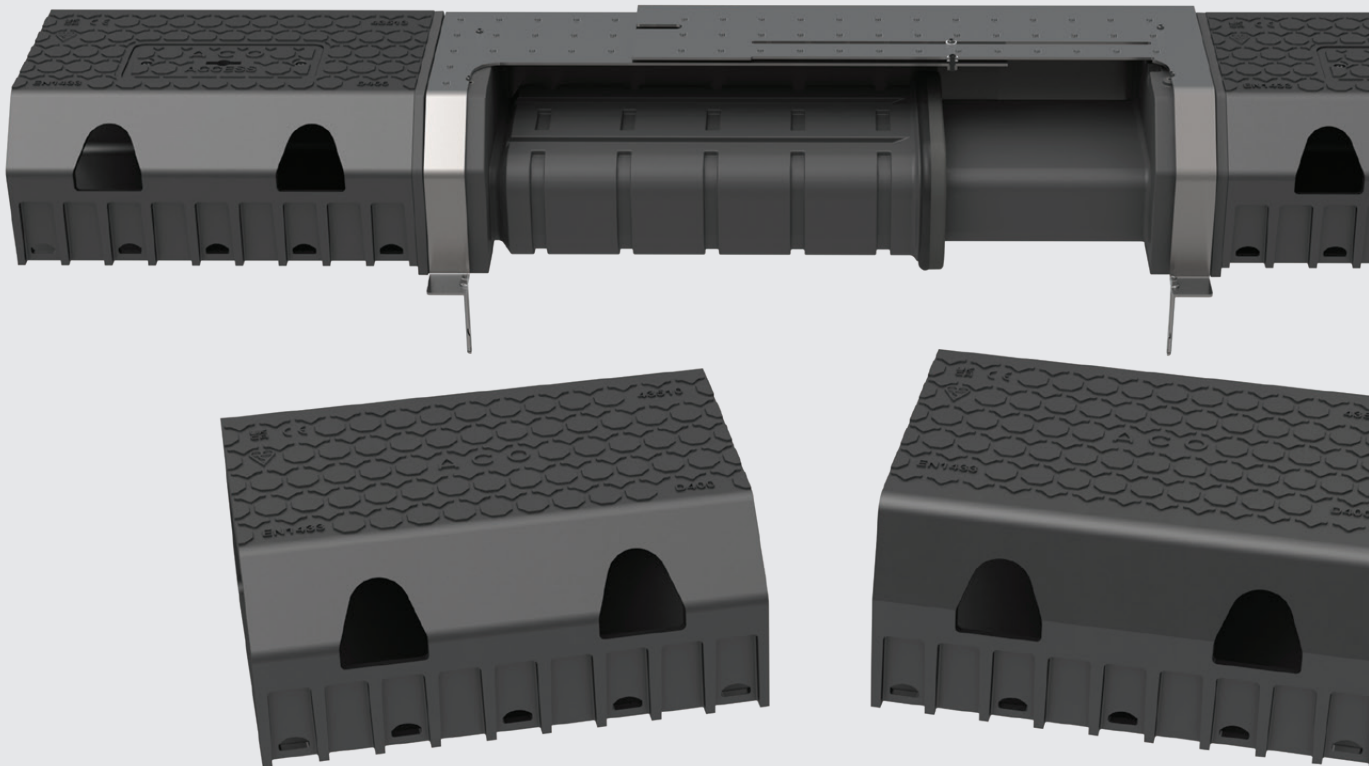

ACO. we care for water	4
What is ACO KerbDrain® BridgeDeck?	6
Why choose ACO KerbDrain® BridgeDeck	8
ACO KerbDrain® BridgeDeck features overview	10
A range of solutions with ACO KerbDrain® BridgeDeck	13
ACO QuAD Hydraulic Design Software	14
ACO KerbDrain® BridgeDeck system overview	16
Cross sectional area details	17
ACO KerbDrain® BridgeDeck HB	18
ACO KerbDrain® BridgeDeck SP	21
Channel installation detail	24
Half Battered expansion joint	26
Half Battered expansion joint installation detail	28
Splayed expansion joint	30
Splayed expansion joint installation detail	32
Outlet connectors	34
Multifunctional end caps	36
Maintenance of ACO KerbDrain® BridgeDeck	38
Associated products and systems	39
Design support service	40
ACO BIM Models	41
Further Learning	42
ACO Professional Development	
Case Studies	
Colab	

# ACO. we care for water

ACO is a Water-Tech company that protects water. Building on our global drainage expertise that protects people from water, we increasingly see our mission as also protecting water from people.

With the ACO WaterCycle, ACO provides systems that collect and channel, clean, retain and ultimately reuse water. In this way, ACO contributes to the preservation of clean groundwater as a vital resource, and makes a contribution to tomorrow's world. In its Agenda 2030, the UN global community set the improvement of water quality as one of 17 sustainable development goals.

Intelligent drainage systems from ACO increasingly use smart technology to ensure that rainwater and wastewater are drained, or temporarily stored. With innovative separation and filter technology, we prevent water contamination by pollutants such as fat and grease, fuels, heavy metals and microplastics.

Today, ACO goes one step further: we accept the challenge of reusing water, and thus establishing a resource-saving cycle. For all products and systems, ACO attaches great importance to durability, reusability and a low carbon footprint. The pursuit of sustainability is an ongoing process that we strive to meet every day.

The ACO Group is a global family business that is one of the world market leaders in the Water-Tech segment. Founded in Schleswig-Holstein in 1946, it operates as a transnational network in over 50 countries. Worldwide, ACO is characterised by a high level of decentralised ownership, and explicit regional market proximity.

[www.aco.com](http://www.aco.com)



Holder  
Iver and Hans-Julius Ahlmann



Headquarters of the ACO Group  
in Rendsburg/Büdelndorf



**5,200**

employees in more than 47 countries (Europe, North and South America, Asia, Australia, Africa)

**1 Billion**

Euro Sales in 2021

**37**

production sites in 18 countries



ACO Academy  
for practical training

## Rainwater management and bridge protection

### What is ACO KerbDrain® BridgeDeck?

Effective management of surface water on bridges is crucial for ensuring road user safety, reducing maintenance costs, and preventing erosion that can shorten the service life of bridge structures.



The ACO KerbDrain® Bridgedeck is a versatile combined kerb and drainage system designed to effectively manage rainwater on bridges. These one-piece units are certified up to Load Class D 400 and are available in both Half Battered (HB) and Splayed profiles (SP) to meet different site requirements.

The product is manufactured from ductile iron and is a Type I system, which means that no concrete bed surround is required for installation. Additionally, the range includes expansion joint solutions that prevent water damage to the joints and allow the flow of water to continue from the bridge to the highway.



# Why choose ACO KerbDrain® BridgeDeck

The system provides a range of integrated channels and problem-solving components, ideal for managing surface water on bridge decks.

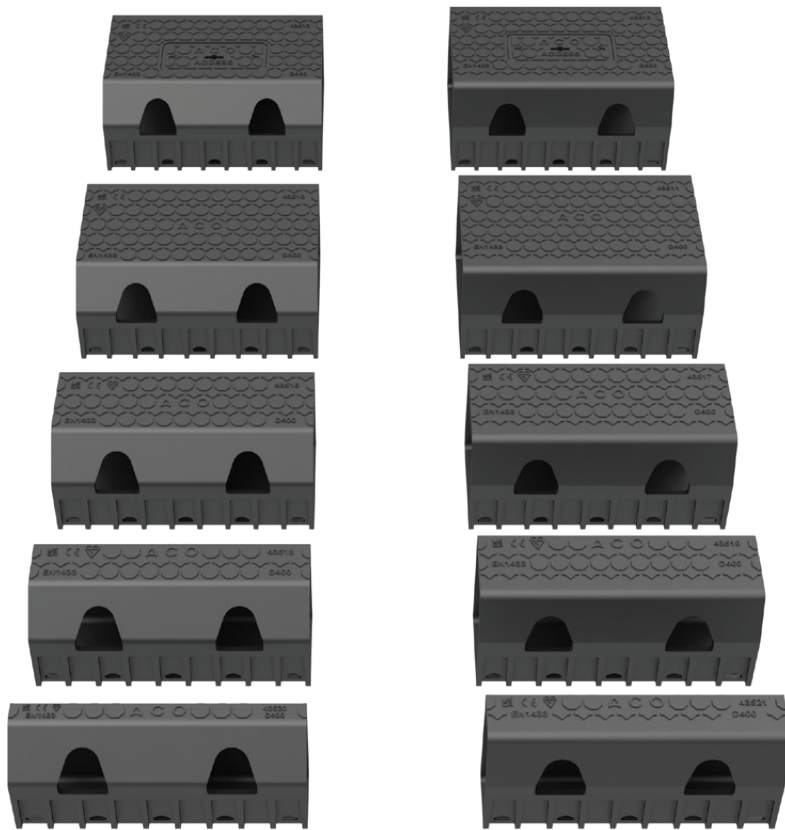

## Product features

- Complete product offering for all bridge types
- Half Battered and Splayed kerb profiles available to suit specific site requirements
- Type I installation meaning no concrete bed surround is required for install
- Certified to BS EN 1433:2002 Load Class D 400
- Sub-surface drainage points for permeable surfaces
- BridgeDeck units can be installed at two different upstand heights
- Can be used as a stand-alone solution or combined with other ACO KerbDrain® channels to create a seamless and integrated solution for bridge and highway schemes

## Conformity

The ACO KerbDrain® BridgeDeck system is UKCA and CE marked, and carries the BSI Kitemark in accordance with the construction products regulation.

Declarations of Performance certificates are available to download on our website:  
[www.aco.co.uk/construction-products-regulation-\(cpr\)](http://www.aco.co.uk/construction-products-regulation-(cpr))

**BS EN 1433:2002**





**BridgeDeck profiles**

ACO KerbDrain® BridgeDeck Splayed (SP) and ACO KerbDrain® BridgeDeck Half Battered (HB)

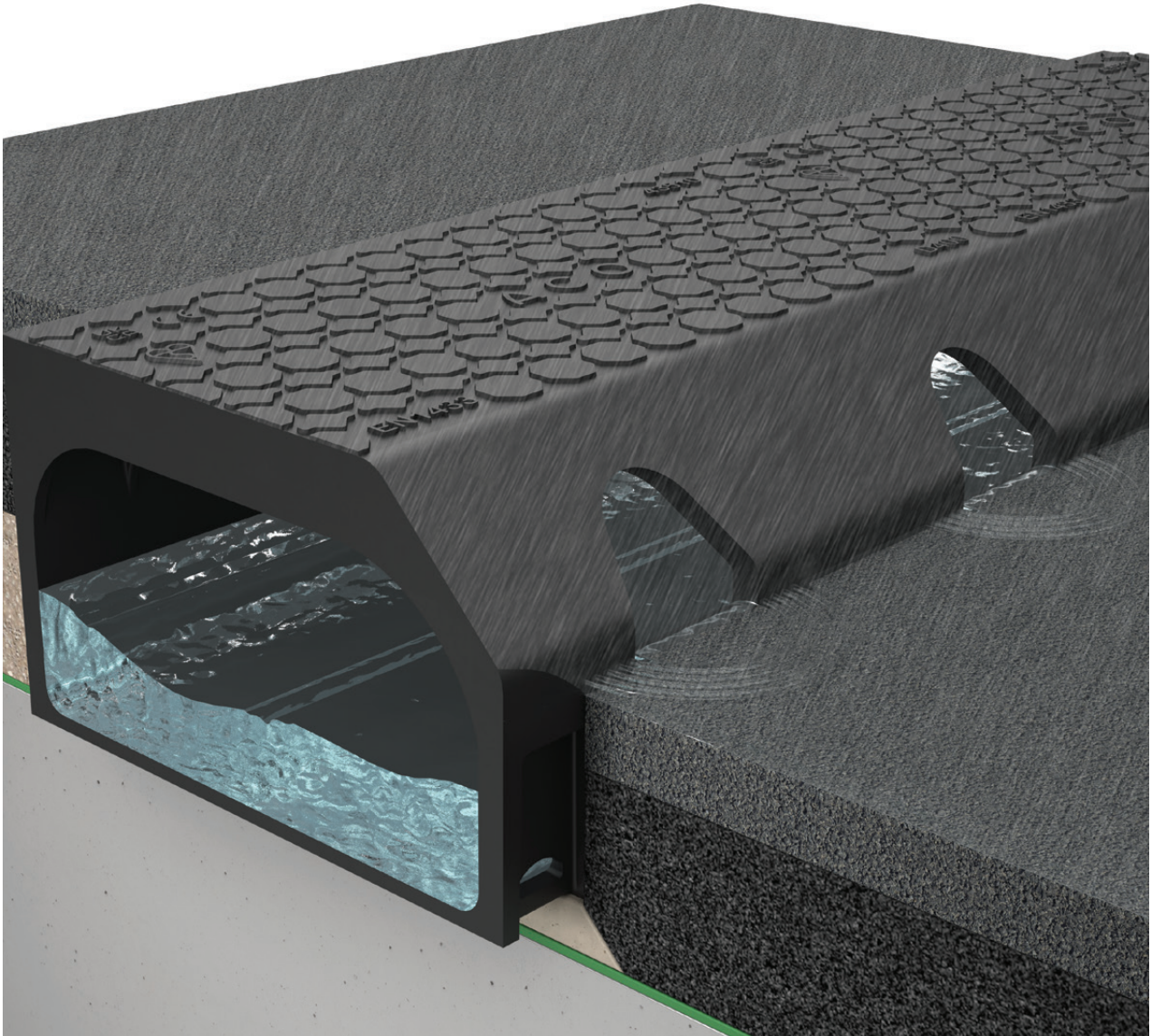

ACO KerbDrain® BridgeDeck is available in both Half Battered and Splayed profiles, each with their own set of problem-solving components ranging from access units to ensure the system can be effectively maintained, as well as outlet connectors and multifunctional end caps.



Access unit



Outlet connectors



Multifunctional end caps

# ACO KerbDrain® BridgeDeck features overview

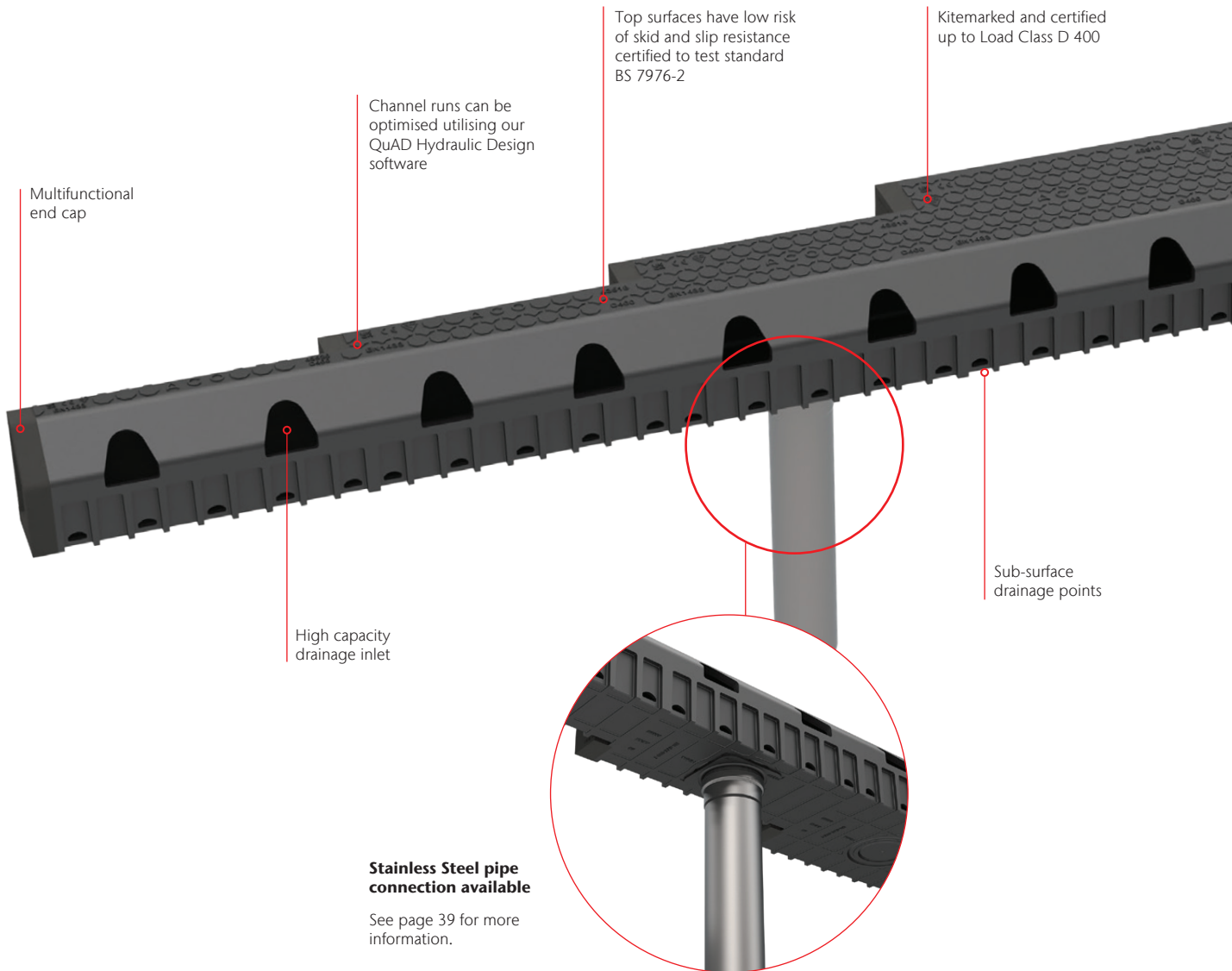

## Bespoke Options

We can tailor our BridgeDeck units to meet specific bespoke design requirements, ensuring the optimum solution for your project. For more information, please call our team on **01462 816666** or email **awmprojects@aco.co.uk**

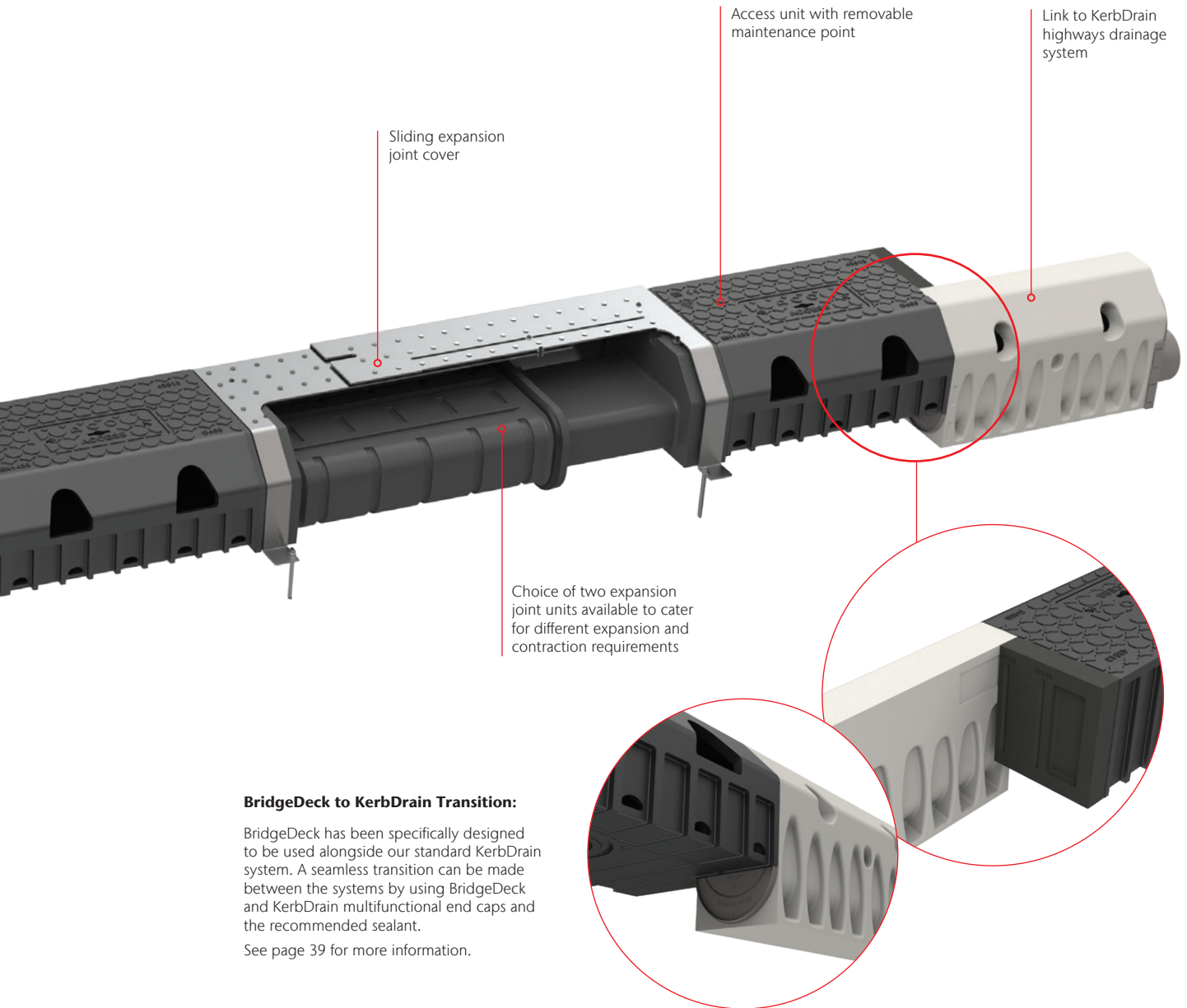

**BridgeDeck to KerbDrain Transition:**

BridgeDeck has been specifically designed to be used alongside our standard KerbDrain system. A seamless transition can be made between the systems by using BridgeDeck and KerbDrain multifunctional end caps and the recommended sealant.

See page 39 for more information.

**Load Classes**



**A 15**  
Pedestrians and cycleways



**B 125**  
Pedestrian precincts, light vehicles, private car parks and drives



**C 250**  
Parking areas, service stations (cars) and slow-moving light commercial vehicles



**D 400**  
Public highways, parking areas for all types of vehicles, distribution yards



# A range of solutions with ACO KerbDrain® BridgeDeck



## Footbridge

The smaller sized units make the BridgeDeck an ideal solution for foot or cycle bridges where the bridge tends to be smaller in size and therefore carrying less volume of water. The Type I installation of the BridgeDeck units make this an ideal system for use where there is little to no kerb line, as you often find on foot and cycle bridges.



## Viaduct

The BridgeDeck channel, with its dedicated expansion joint solution, is the ideal system for projects where multiple piers and connections between sections of a viaduct are required. The outlet options on the underside of the channels also offer multiple points for pipe connections in both 110mm and 160mm diameter.



## Road bridge

BridgeDeck comes in a range of channel sizes, making it the ideal solution for road bridges; from single lane rural road bridges, to multi-lane highway bridges. Having the flexibility to mix and match sizes to meet specific hydraulic requirements, as well as the ability to connect BridgeDeck to other KerbDrain systems, means that this is the perfect solution for roads where linking bridge drainage to highway drainage can be challenging.



## Refurbishment or new build

The BridgeDeck channel system can be installed on new bridges as well as retrofitted on refurbished bridge schemes. Its black ductile iron finish offers an antique look that complements the aesthetics of older bridge structures. For newer bridges, the black finish provides a more modern appearance.

# ACO QuAD Hydraulic Design Software

Try our free design tool

The free-to-use ACO QuAD Hydraulic Design software has unprecedented levels of choice and flexibility built-in, to enable the efficient and accurate hydraulic design of any surface water management scheme. Use the tool today to help you to design bridge schemes using ACO KerbDrain® and ACO KerbDrain® BridgeDeck.



The hydraulic engine has been robustly tested and is the tool used by ACO's internal Design Services Team in modelling surface water solutions for customers.

ACO QuAD Hydraulic Design software uses differential equations for spatially varied flow that online alternative solutions cannot accurately match. For example the Manning's equation for steady uniform flow does not work with level channels and is grossly inaccurate on shallow gradients.

Here are some of the features it includes:

- Powerful project-based software
- Create catchment models that are fully editable
- PDF summary document output
- Cloud based – all designs are stored securely on our server against your login
- Integrated rainfall data for the whole of the UK

## QuAD Features Overview

### Cloud based

The software means increased efficiency providing the design resources you need when you need it, allowing you to deploy the same design capability consistently, and with the same consistency in results every time.



### Flexible catchment design

QuAD supports designers in creating catchment areas. Supplementary catchment areas can be easily added to previously designed channel runs, providing flexibility when designing upstream and downstream features.



### Product + value optimiser

Optimising the specific channel runs can be done with the optimiser feature selecting the smallest product suitable. Excavation and concrete requirements are also provided.



### Attenuation assessments

Calculate the attenuation required for the project and compare it with the storage available in the channel design. Attenuation volume is presented along with suitable options for storage.



### Flexible download format

Output can be generated for all or parts of the project and can be generated in pdf or CSV formats.



### Application

Application selection ensure designers are able to get quick and accurate guidance in selection of the most suitable products based on the type of application the catchment is to cater for.



### Rainfall assist

Rainfall intensity by location matters in design. QuAD provides a site locator map enabling the most accurate intensity to be input.



### Resilience assessment

By inputting anticipated sedimentation rates and sedimentation density the QuAD software enables the designer to test their suggested maintenance schedules.



### Secure scheme filing

All designs created by registered users are stored on a secure server and are password protected. Past projects are easily retrieved from the personalised menu.



### Knowledge + support

Technical and design support is available through the askACO Knowledge Base (self-help), askACO live chat or through a Design submission form.



# ACO KerbDrain® BridgeDeck system overview

ACO KerbDrain® BridgeDeck is available in Half Battered (HB) or Splayed (SP) profiles and has a variety of unit widths available for optimum scheme hydraulics.

To summarise the available options, the product selector below displays key features for each of the profiles and unit widths available.

Once product selection has been made based on the features required, the table will direct you to the appropriate page.

ACO KerbDrain® BridgeDeck:

- Available in Half Battered (HB) or Splayed (SP) profiles
- Choice of unit widths
- Manufactured from ductile iron
- Has dedicated expansion joint solutions







HB PROFILE	HB100	HB160	HB240	HB360
	Page 19 	Page 19 	Page 19 	Page 20 
UNIT WIDTH	<b>115mm</b>	<b>166mm</b>	<b>233mm</b>	<b>355mm</b>
HYDRAULIC CAPACITY				
CROSS SECTIONAL AREA	<b>10074mm<sup>2</sup>*</b>	<b>16092mm<sup>2</sup>*</b>	<b>23939mm<sup>2</sup>*</b>	<b>36030mm<sup>2</sup>*</b>
0.5M UNIT				
TRANSITIONS TO	<b>ALL SIZES</b>			

\* Cross sectional area based on upstand height of 100mm

SP PROFILE	SP100	SP160	SP240	SP360
	Page 22 	Page 22 	Page 22 	Page 23 
UNIT WIDTH	<b>115mm</b>	<b>166mm</b>	<b>233mm</b>	<b>355mm</b>
HYDRAULIC CAPACITY				
CROSS SECTIONAL AREA	<b>10185mm<sup>2</sup>*</b>	<b>16280mm<sup>2</sup>*</b>	<b>23942mm<sup>2</sup>*</b>	<b>36190mm<sup>2</sup>*</b>
0.5M UNIT				
TRANSITIONS TO	<b>ALL SIZES</b>			

\* Cross sectional area based on upstand height of 75mm

<b>AVAILABILITY</b>  AVAILABLE  NOT AVAILABLE	<b>HYDRAULIC CAPACITY</b>  LOW  MEDIUM  HIGH	<b>LOAD CLASS D 400</b> LOAD CLASS D 400 PUBLIC HIGHWAYS, PARKING AREAS FOR ALL TYPES OF VEHICLES, DISTRIBUTION YARDS
---	--	--



## Cross sectional area details

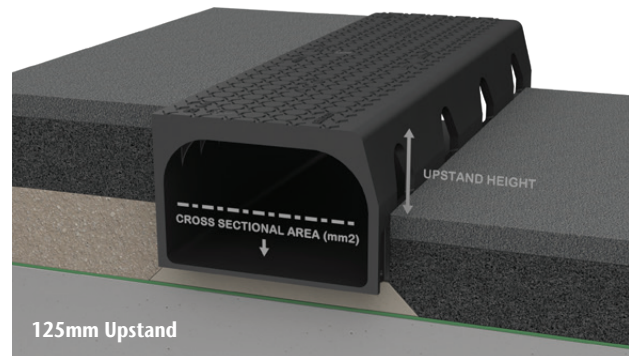
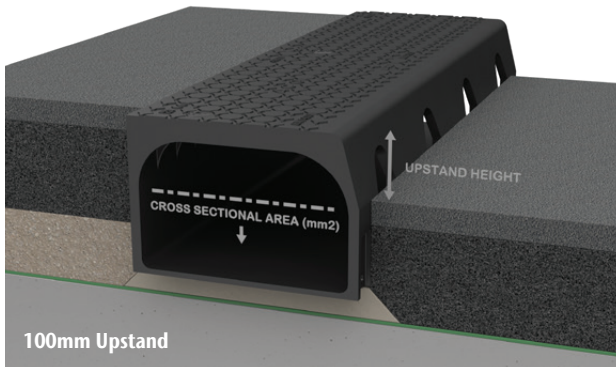

Product Code	Description	Dimensions [mm]	100mm Upstand [mm <sup>2</sup> ]	125mm Upstand [mm <sup>2</sup> ]
<b>ACO KerbDrain® BridgeDeck - cross sectional area (mm<sup>2</sup>) Half Battered</b>				
43521	HB100 KerbDrain BridgeDeck channel	500 x 115 x 226	10074	7925
43519	HB160 KerbDrain BridgeDeck channel	500 x 166 x 226	16092	12668
43517	HB240 KerbDrain BridgeDeck channel	500 x 233 x 226	23939	18852
43511	HB360 KerbDrain BridgeDeck channel	500 x 335 x 226	36030	28385

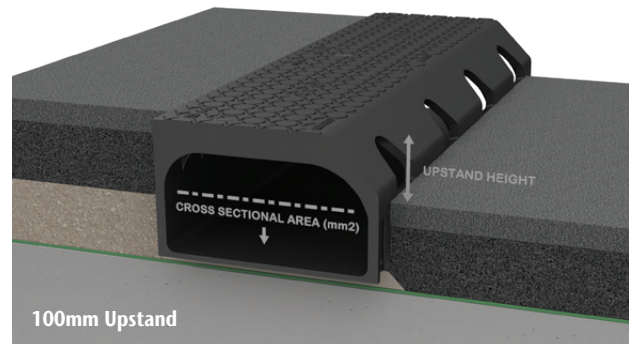
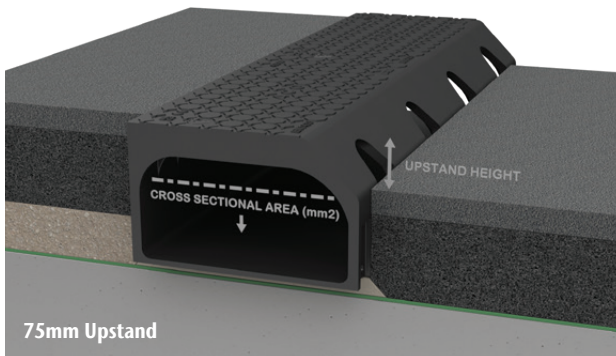

Product Code	Description	Dimensions [mm]	75mm Upstand [mm <sup>2</sup> ]	100mm Upstand [mm <sup>2</sup> ]
<b>ACO KerbDrain® BridgeDeck - cross sectional area (mm<sup>2</sup>) Splayed</b>				
43520	SP100 KerbDrain BridgeDeck channel	500 x 115 x 203	10185	8054
43518	SP160 KerbDrain BridgeDeck channel	500 x 166 x 203	16280	12873
43516	SP240 KerbDrain BridgeDeck channel	500 x 233 x 203	23942	19142
43510	SP360 KerbDrain BridgeDeck channel	500 x 335 x 203	36190	28828

# ACO KerbDrain® BridgeDeck HB







The ACO KerbDrain® BridgeDeck Half Battered range is designed with a HB profile, ensuring safety by deflecting vehicles travelling at low speeds back into the main carriageway and away from pedestrians. The range is ideal for all types of bridge structures, from footbridges to viaducts.

BridgeDeck is available in four different widths, all in 0.5m lengths, and is compatible for use with our other Half Battered KerbDrain product solutions, ensuring a seamless transition between systems. The following components are available:

- 110mm and 160mm outlet connectors
- Multifunctional end caps
- Two options of expansion joint units



	HB Profile		Load Class
115mm, 166mm, 233mm & 335mm	Unit Width		Stocked
	Hydraulic Capacity		BS EN1433

# ACO KerbDrain® BridgeDeck HB

Product Code	Description	Length [mm]	Width Overall [mm]	Depth [mm]	Invert Depth [mm]	Weight [kg]
--------------	-------------	----------------	-----------------------	---------------	----------------------	----------------

## HB100 ACO KerbDrain® BridgeDeck channel (ductile iron - black)

43521	HB100 KerbDrain BridgeDeck channel	500	115	226	218	21.1
-------	------------------------------------	-----	-----	-----	-----	------

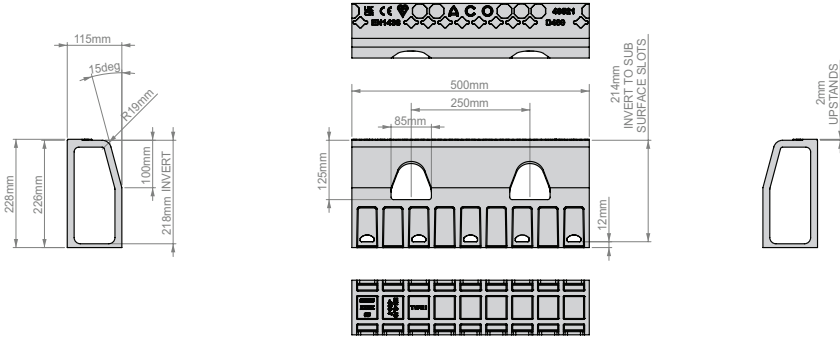

## HB160 ACO KerbDrain® BridgeDeck channel (ductile iron - black)

43519	HB160 KerbDrain BridgeDeck channel	500	166	226	218	25.7
-------	------------------------------------	-----	-----	-----	-----	------

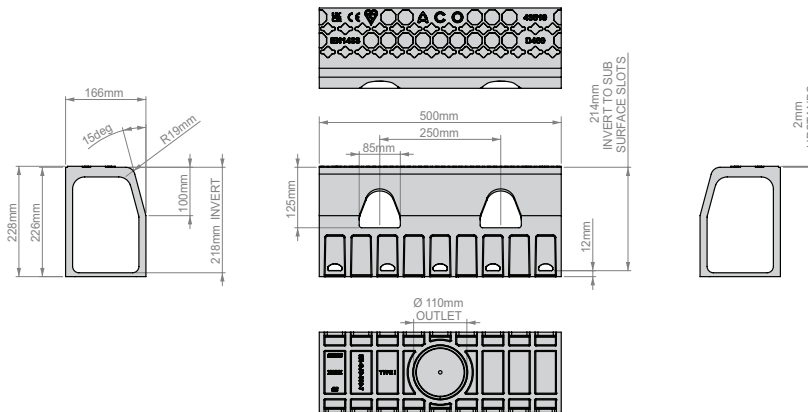

## HB240 ACO KerbDrain® BridgeDeck channel (ductile iron - black)

43517	HB240 KerbDrain BridgeDeck channel	500	233	226	218	31.5
-------	------------------------------------	-----	-----	-----	-----	------

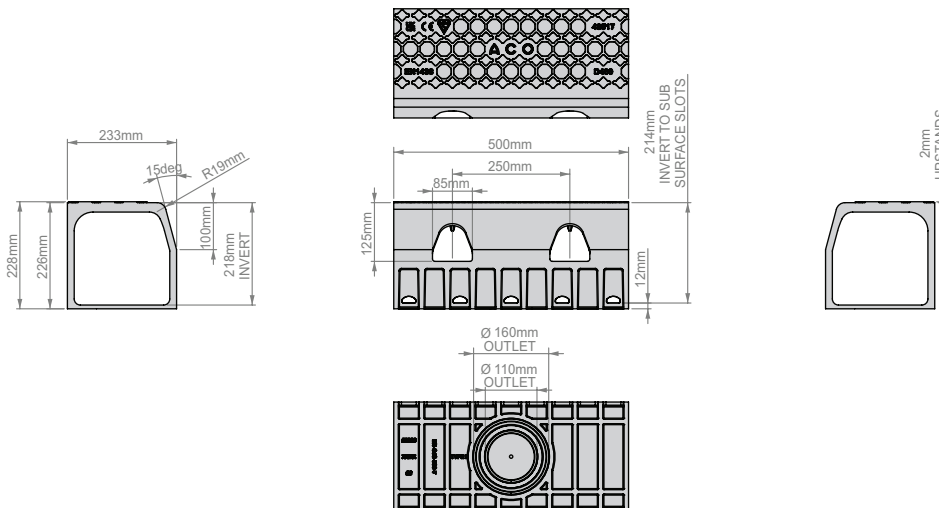

## ACO KerbDrain® BridgeDeck HB

Product Code	Description	Length [mm]	Width Overall [mm]	Depth [mm]	Invert Depth [mm]	Weight [kg]
<b>HB360 ACO KerbDrain® BridgeDeck channel (ductile iron - black)</b>						
43511	HB360 KerbDrain BridgeDeck channel	500	335	226	218	42.9

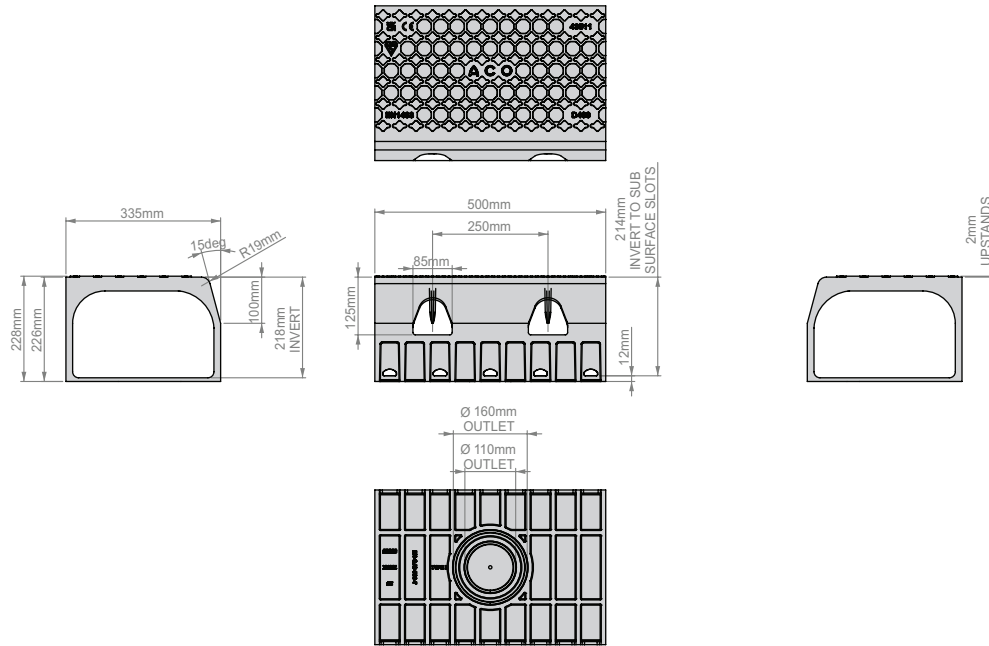

<b>HB360 ACO KerbDrain® BridgeDeck access unit (ductile iron - black)</b>						
43512	HB360 KerbDrain BridgeDeck access unit	500	335	226	218	44.0

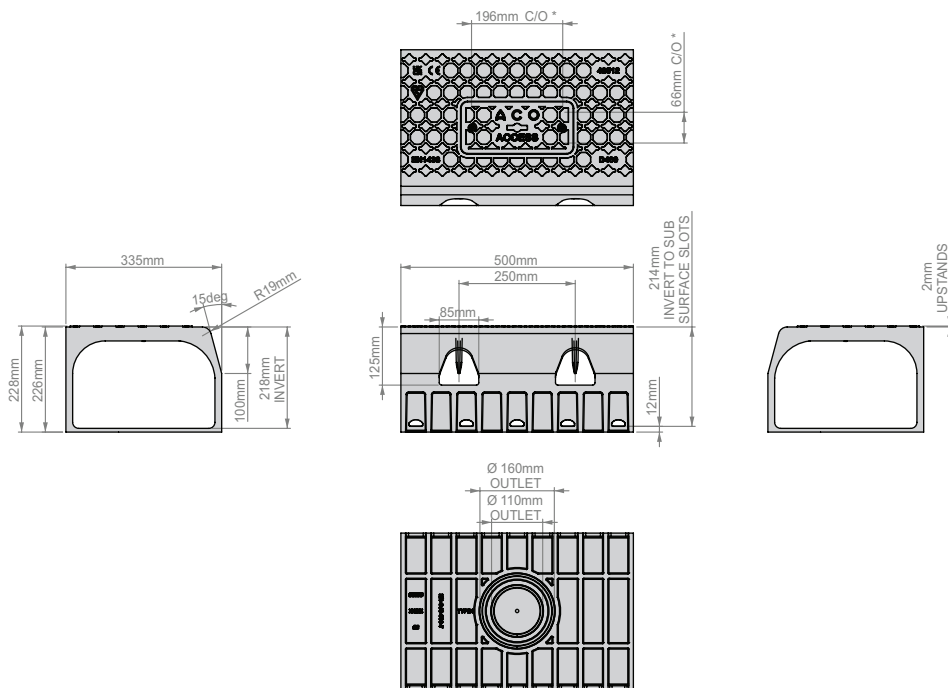

# ACO KerbDrain® BridgeDeck SP







The ACO KerbDrain® BridgeDeck Splayed range is designed with a SP profile, ensuring safety by allowing vehicles travelling at high speeds to mount the kerb, preventing them from deflecting back onto the carriageway. The range is ideal for all types of bridge structures but should only be used where there are no footpaths, should vehicle traffic be present.

ACO KerbDrain® BridgeDeck is available in four different widths, all in 0.5m lengths, and is compatible for use with our other Half Battered KerbDrain product solutions, ensuring a seamless transition between systems. The following components are available:

- 110mm and 160mm outlet connectors
- Multifunctional end caps
- Two options of expansion joint units



 SP Profile	 Load Class
115mm, 166mm, 233mm & 335mm Unit Width	 Stocked
 Hydraulic Capacity	 BS EN1433

## ACO KerbDrain® BridgeDeck SP

Product Code	Description	Length [mm]	Width Overall [mm]	Depth [mm]	Invert Depth [mm]	Weight [kg]
<b>SP100 ACO KerbDrain® BridgeDeck channel (ductile iron - black)</b>						
43520	SP100 KerbDrain BridgeDeck channel	500	115	203	195	18.0

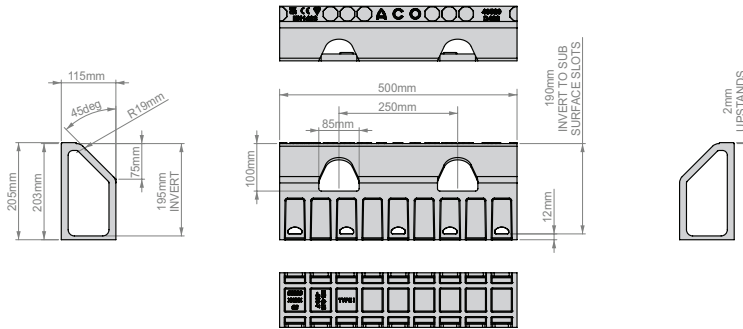

<b>SP160 ACO KerbDrain® BridgeDeck channel (ductile iron - black)</b>						
43518	SP160 KerbDrain BridgeDeck channel	500	166	203	195	22.5

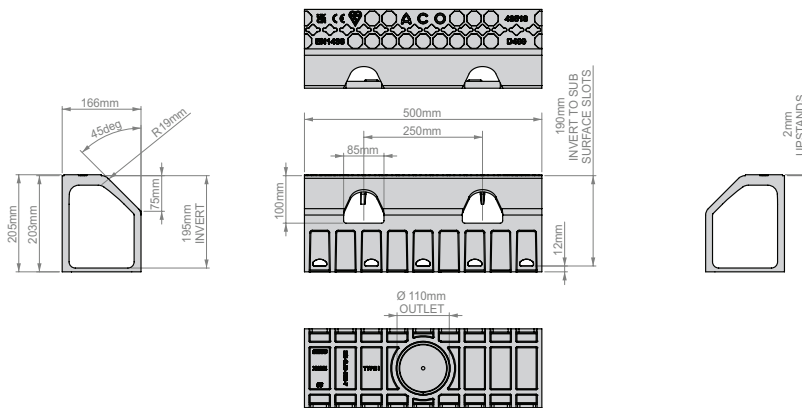

<b>SP240 ACO KerbDrain® BridgeDeck channel (ductile iron - black)</b>						
43516	SP240 KerbDrain BridgeDeck channel	500	233	203	195	31.0

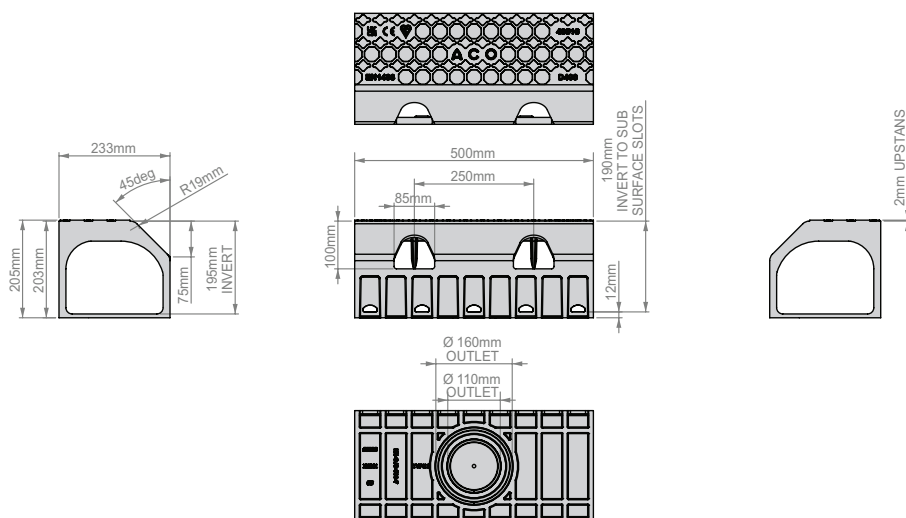

# ACO KerbDrain® BridgeDeck SP

Product Code	Description	Length [mm]	Width Overall [mm]	Depth [mm]	Invert Depth [mm]	Weight [kg]
<b>SP360 ACO KerbDrain® BridgeDeck channel (ductile iron - black)</b>						
43510	SP360 KerbDrain BridgeDeck channel	500	335	203	195	41.7

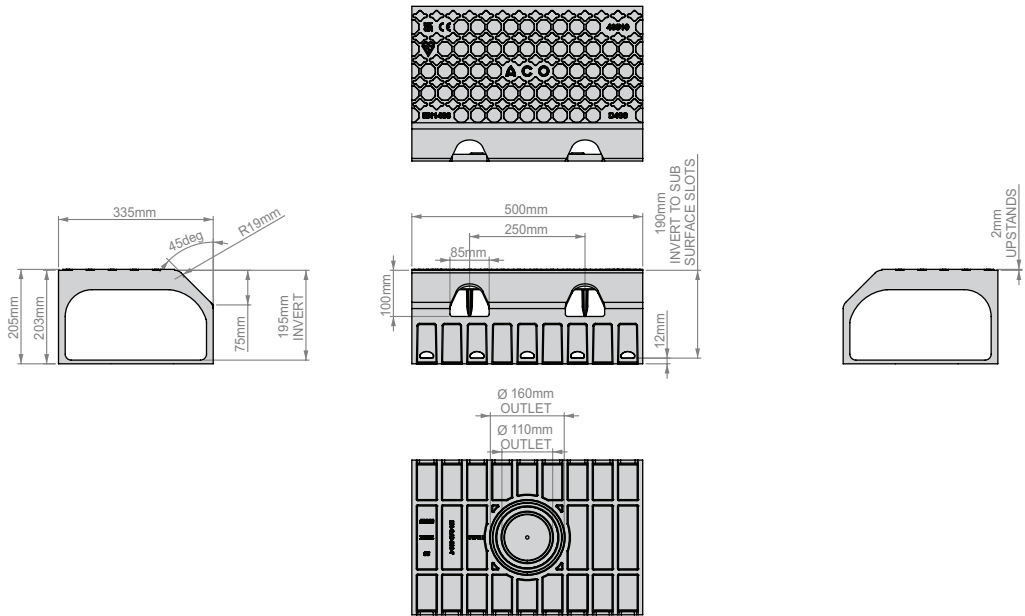

<b>SP360 ACO KerbDrain® BridgeDeck access unit (ductile iron - black)</b>						
43513	SP360 KerbDrain BridgeDeck access unit	500	335	203	195	43.8

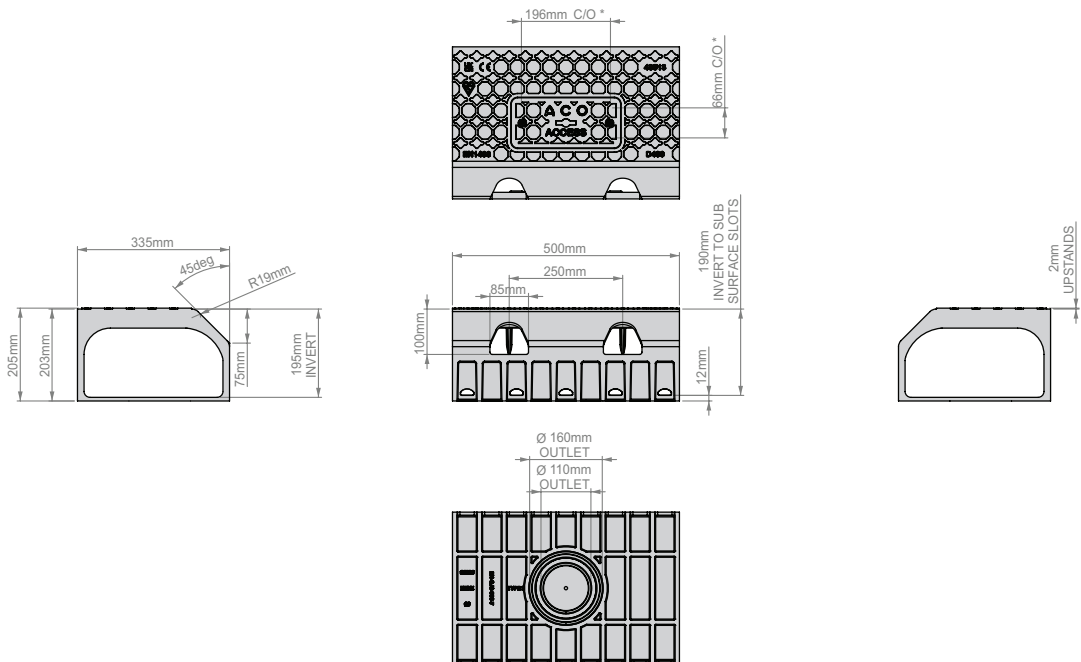

# Channel installation detail

## Load class

Installation recommendations shown are ACO minimum recommendations for BS EN 1433:2002 D 400 Type I load class requirements.

## Ground conditions

The long term performance of a channel installation to sustain vertical and lateral loads depends upon A) bridge deck conditions B) stability of the adjacent pavement and C) a durable mortar bed.

## Cutting and jointing

Mitre joints are formed by cutting the channels to the required angle and butting them together with appropriate sealant (e.g. Sikaflex 11FC Purform or similar). For further details please contact ACO Design Services Team. Avoid cutting through the inlet aperture, we recommend any cuts should be a minimum of 25mm away.

## Block pavements

Blocks or slabs bedded on sand remote from the channel should be set at a higher level to compensate for possible settlement of the paving in service.

## Installation upstand heights

The dimension (X), as shown within the detail, shows different upstand heights for each profile. This would be governed by the kerb upstand required for the highway. The channels should always be installed with a kerb face height of between 100mm and 125mm for Half Battered and between 75mm and 100mm for Splayed KerbDrain® BridgeDeck.

## Watertight installation to BS EN 1433:2002

Where ACO channel joints/fittings and channel/pavement interfaces are to be sealed, an appropriate sealant should be used (e.g. Sikaflex 11FC Purform or similar). Guidance on the necessary surface preparation and/or priming should be sought from the sealant manufacturer.

For guidance a typical method of application follows:

- The end faces of the channels are to be sound and free from dust, oil, and grease, with any loose material or dirt removed, e.g. by mechanical wire brush. No water drops should be evident.
- Using a standard cartridge gun, apply the sealant evenly and with no flaws. The detail on the ends of a channel varies from one product to another.
- Products with a basically flat face - apply the sealant in a layer approximately 5mm thick to one face of the joint.
- Products with a sealing groove within the end face - apply the sealant in a bead of approximately 10mm diameter into the sealing groove.
- Products with a sealing groove following the inside shape of the channel - apply the sealant to the end face of the channel and to the sealant groove, such that when the joint is completed, the sealant will both cover the end face and fill the groove.
- The channel unit should be placed on the prepared concrete or mortar bedding and pressed against the previously placed channel unit. A sealed joint of approximately 1-2mm width should be formed between adjacent channel units.
- Excess sealant should be wiped from the inside face of the channel to leave a smooth finish.
- The sealant is to be left to cure for 24 hours, during which time the sealant should be kept as dry as possible.



**ACO KerbDrain® BridgeDeck half battered channel installation**

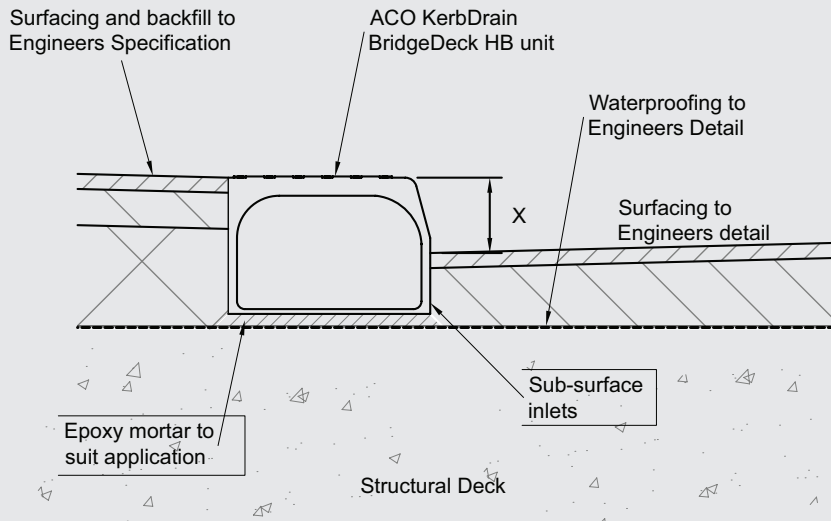

**ACO KerbDrain® BridgeDeck splayed channel installation**

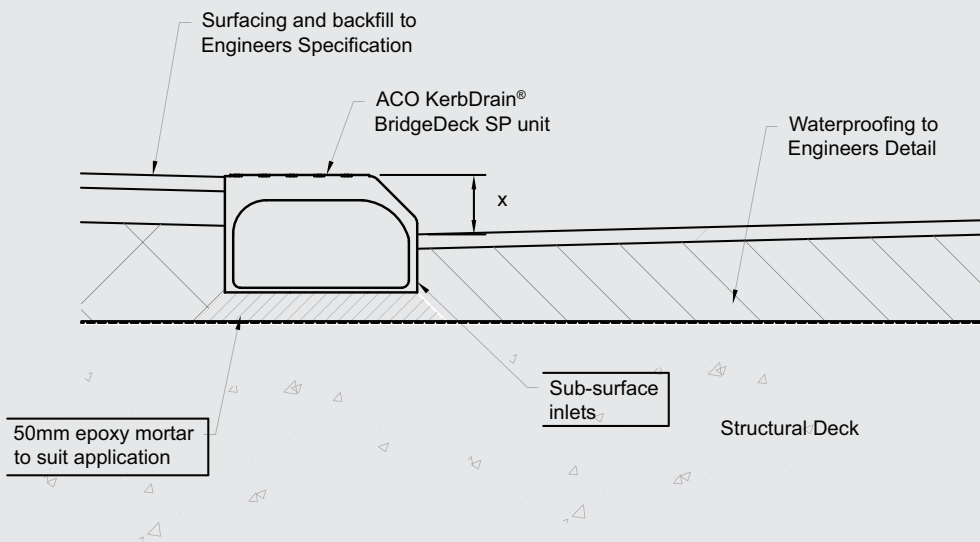

(x: BridgeDeck upstand to suit application - See 'Installation Upstand Heights' Note)

# Half Battered expansion joint

ACO KerbDrain® BridgeDeck Half Battered Moulded Expansion Joint (section view)

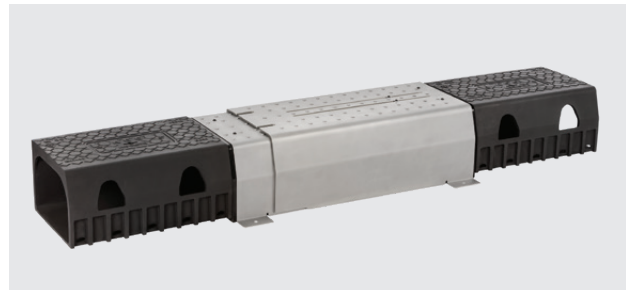

Product Code	Description	Length [mm]	Width Overall [mm]	Depth [mm]	Invert Depth [mm]	Weight [kg]	Expansion Range [mm]
--------------	-------------	----------------	-----------------------	---------------	----------------------	----------------	-------------------------

**ACO KerbDrain® BridgeDeck half battered moulded expansion joint kit (Type 5)**

43553	KerbDrain BridgeDeck moulded expansion joint kit	1754	335	226	218	129.5	0 - 500
-------	--	------	-----	-----	-----	-------	---------

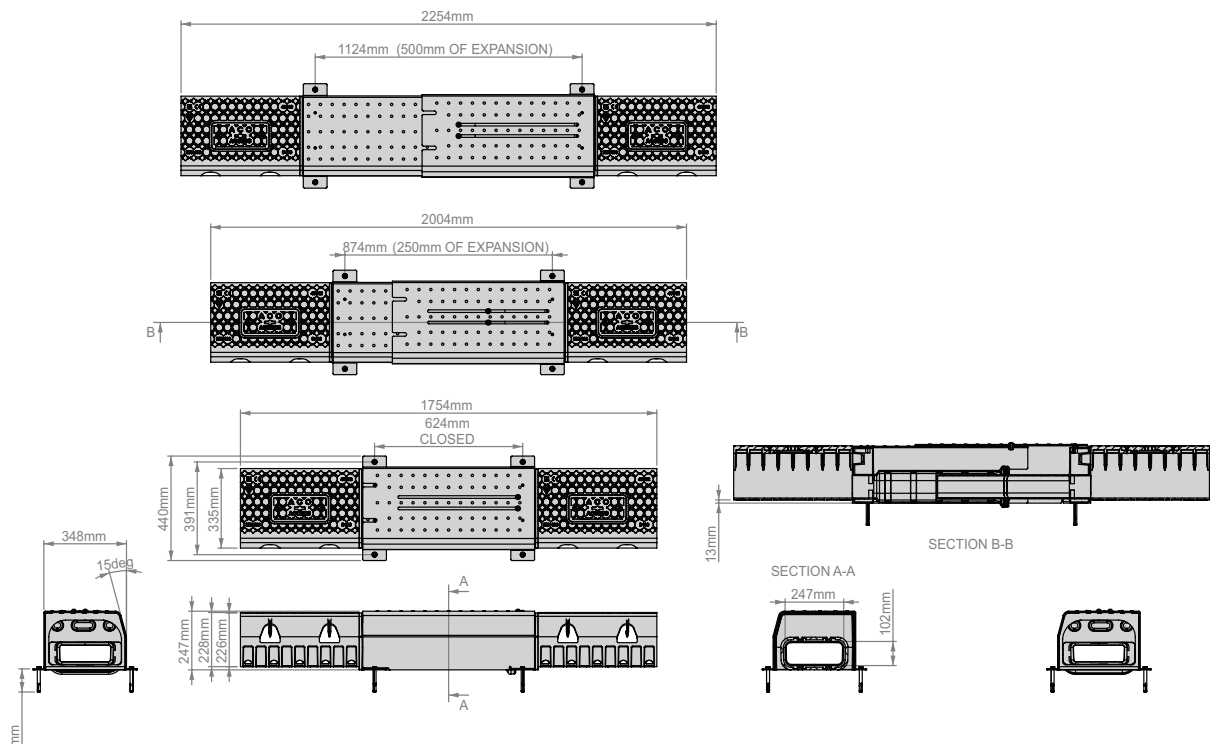

ACO KerbDrain® BridgeDeck Half Battered  
Polymer Expansion Joint (section view)

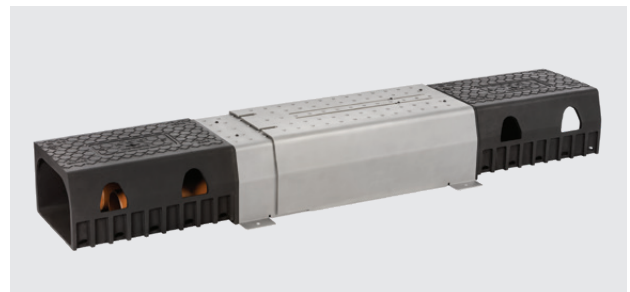
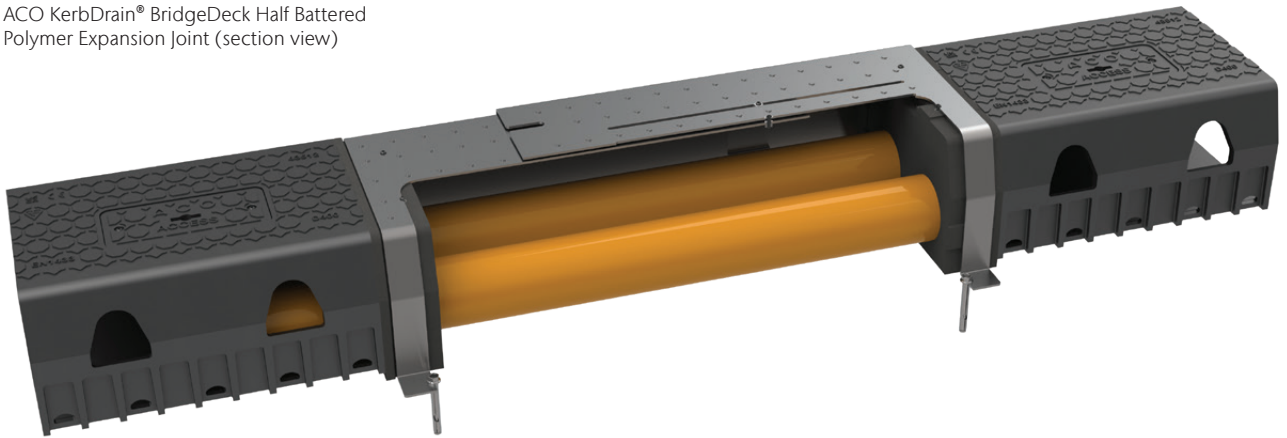

Product Code	Description	Length [mm]	Width Overall [mm]	Depth [mm]	Invert Depth [mm]	Weight [kg]	Expansion Range [mm]
43551	KerbDrain BridgeDeck polymer expansion joint kit	1758	335	226	218	150.1	0 - 300

**ACO KerbDrain® BridgeDeck half battered polymer expansion joint kit (Type 1)**

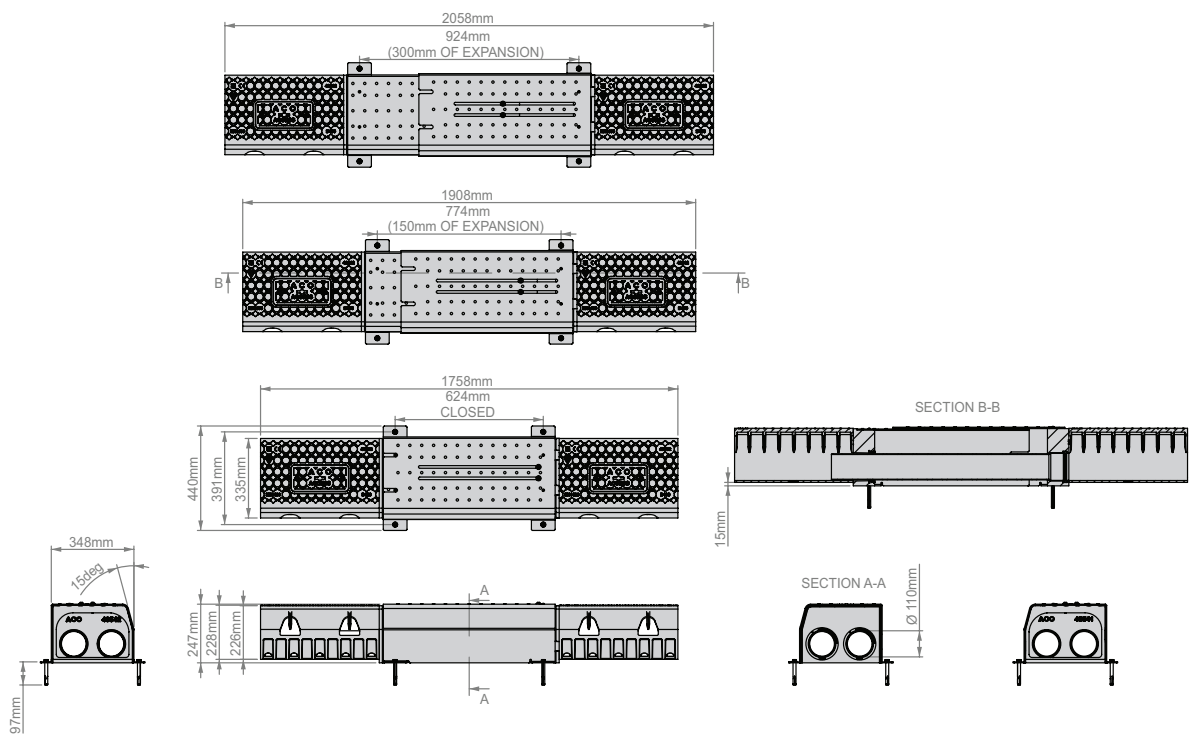

# Half Battered expansion joint installation detail

## Load class

Installation recommendations shown are ACO minimum recommendations for BS EN 1433:2002 load class requirements.

## Ground conditions

The long term performance of a channel installation to sustain vertical and lateral loads depends upon A) bridge deck conditions B) stability of the adjacent pavement and C) a durable mortar bed.

## Cutting and jointing

Mitre joints are formed by cutting the channels to the required angle and butting them together with appropriate sealant (e.g. Sikaflex 11FC Purform or similar). For further details please contact ACO Design Services Team. Avoid cutting through the inlet aperture, we recommend any cuts should be a minimum of 25mm away.

## Block pavements

Blocks or slabs bedded on sand remote from the channel should be set at a higher level to compensate for possible settlement of the paving in service.

## Installation upstand heights

The dimension (X), as shown within the detail, shows different upstand heights for each profile. This would be governed by the kerb upstand required for the highway. The channels should always be installed with a kerb face height of between 100mm and 125mm for Half Battered and between 75mm and 100mm for Splayed KerbDrain BridgeDeck

## Joint lubrication

Prior to installation the joint should be lubricated using a white lithium grease. Once installed, additional lubrication should be applied as part of a regular maintenance regime. Grease can be applied through the use of the Access Unit or in the slots of the expansion joint cover.

## Setting out

As shown within the detail, the location of the BridgeDeck Expansion Joint fixing anchors should take into account site ambient temperature and the likely expansion and contraction of the joint to be encountered following installation. They should also avoid the Bridge Expansion Joint fixings.

## Watertight installation to BS EN 1433:2002

Where ACO channel joints/fittings and channel/pavement interfaces are to be sealed, an appropriate sealant should be used (e.g. Sikaflex 11FC Purform or similar). Guidance on the necessary surface preparation and/or priming should be sought from the sealant manufacturer.

For guidance a typical method of application follows:

- The end faces of the channels are to be sound and free from dust, oil, and grease, with any loose material or dirt removed, e.g. by mechanical wirebrush. No water drops should be evident.
- Using a standard cartridge gun, apply the sealant evenly and with no flaws. The detail on the ends of a channel varies from one product to another.
- Products with a basically flat face - apply the sealant in a layer approximately 5mm thick to one face of the joint.
- Products with a sealing groove within the end face - apply the sealant in a bead of approximately 10mm diameter into the sealing groove.
- Products with a sealing groove following the inside shape of the channel - apply the sealant to the end face of the channel and to the sealant groove, such that when the joint is completed, the sealant will both cover the end face and fill the groove.
- The channel unit should be placed on the prepared concrete or mortar bedding and pressed against the previously placed channel unit. A sealed joint of approximately 1-2mm width should be formed between adjacent channel units.
- Excess sealant should be wiped from the inside face of the channel to leave a smooth finish.
- The sealant is to be left to cure for 24 hours, during which time the sealant should be kept as dry as possible.

The ACO BridgeDeck expansion joint cover and end caps can be set out by measuring the bridge expansion gap on the day of installation. The difference between the joint at 0% expansion and the measurement taken on the day (+10%) will be the amount the cover is opened by. Take the cover in the measured open position and place this equidistant about the bridge expansion joint.

Sequence of Works:

- Set out bolt locations.
- Drill holes and insert anchor bolts with sleeve. Waterproofing seal to be introduced.
- Lay 25mm mortar below fixing flanges and end plates. Ensure mortar bed does not exceed flanges for fixing holes.
- Lay assembled unit onto anchors and mortar.
- Tighten anchor bolts.
- Lay access units on 50mm mortar bed with sealant at joints.

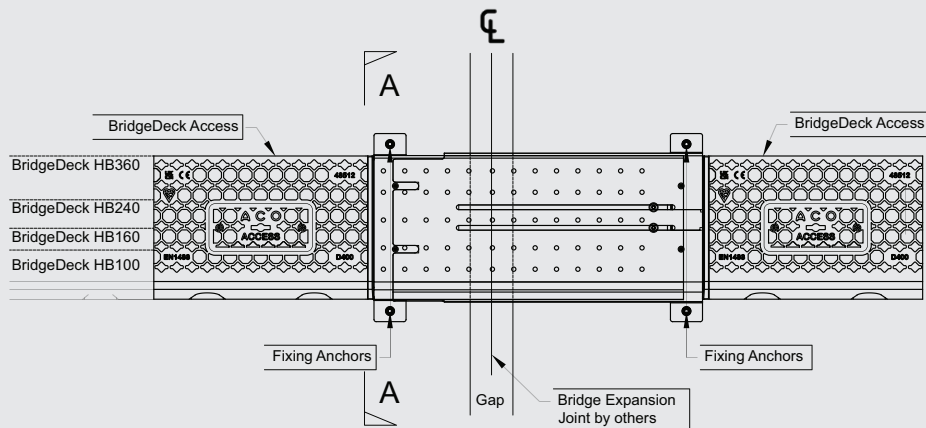

(X: BridgeDeck upstand to suit application - See Note 6.0)

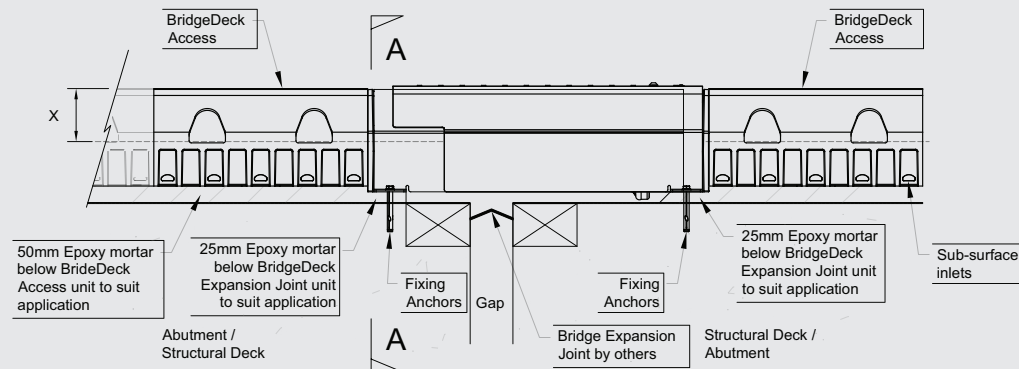

Moulded Expansion Joint (section view)

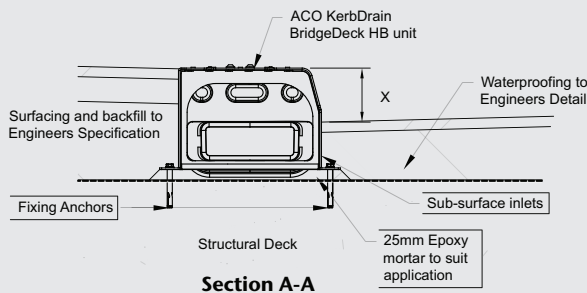

Polymer Expansion Joint (section view)

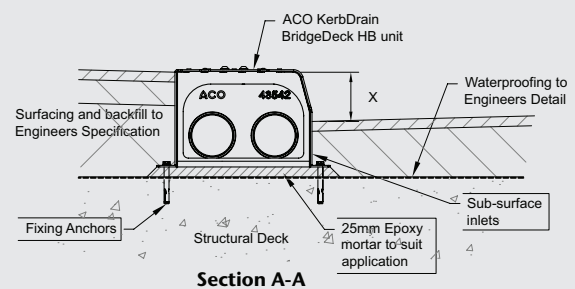

# Splayed expansion joint

ACO KerbDrain® BridgeDeck Splayed  
Moulded Expansion Joint (section view)

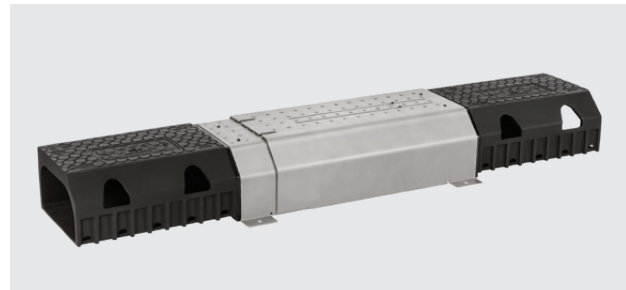

Product Code	Description	Length [mm]	Width Overall [mm]	Depth [mm]	Invert Depth [mm]	Weight [kg]	Expansion Range [mm]
--------------	-------------	----------------	-----------------------	---------------	----------------------	----------------	----------------------------

## ACO KerbDrain® BridgeDeck splayed moulded expansion joint kit (Type 5)

43552	KerbDrain BridgeDeck moulded expansion joint kit	1754	335	203	195	126.3	0 - 500
-------	---	------	-----	-----	-----	-------	---------

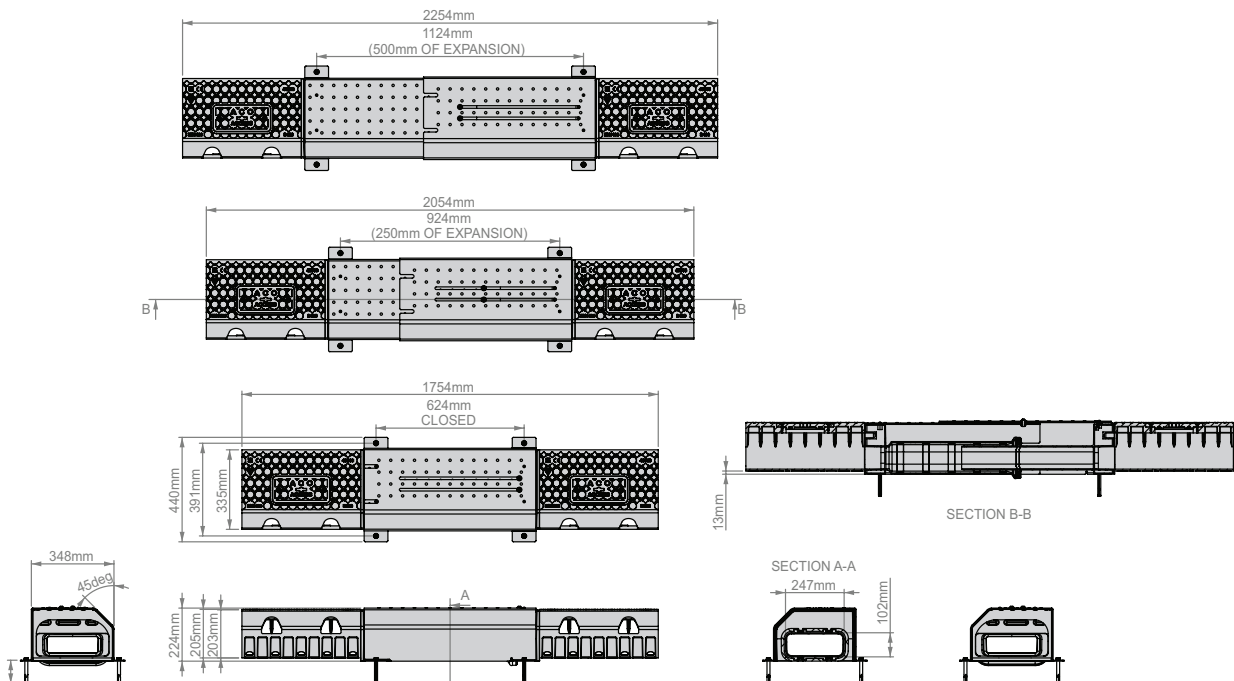

ACO KerbDrain® BridgeDeck Splayed  
Polymer Expansion Joint (section view)

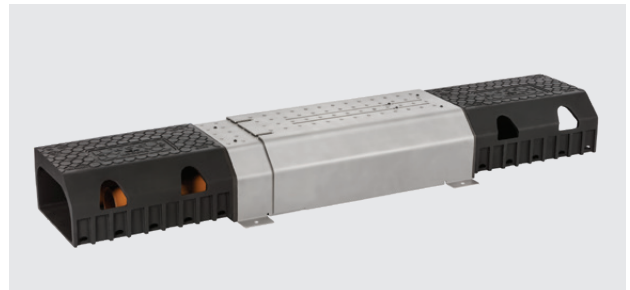
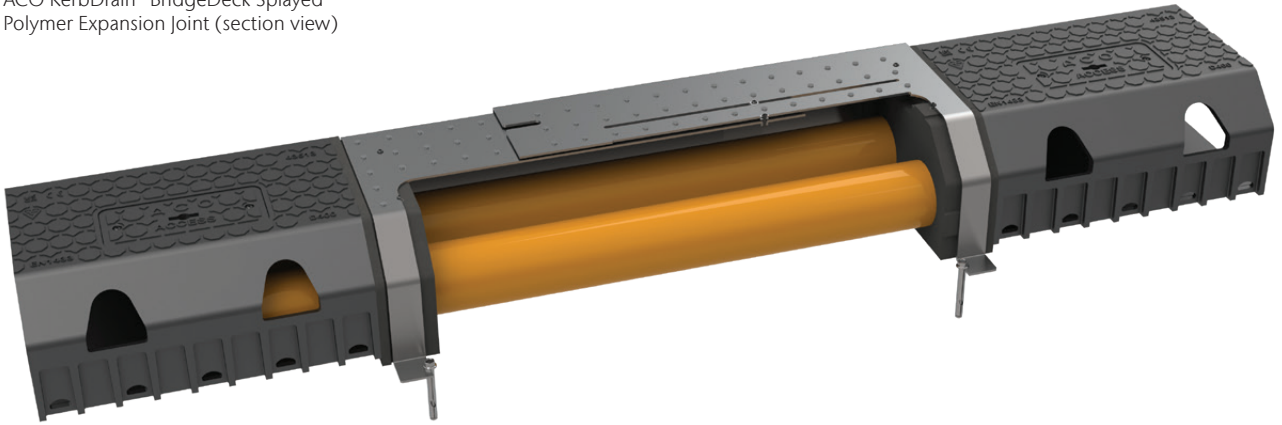

Product Code	Description	Length [mm]	Width Overall [mm]	Depth [mm]	Invert Depth [mm]	Weight [kg]	Expansion Range [mm]
--------------	-------------	----------------	-----------------------	---------------	----------------------	----------------	----------------------------

**ACO KerbDrain® BridgeDeck splayed expansion joint kit (Type 1)**

43550	KerbDrain BridgeDeck polymer expansion joint kit	1758	335	203	195	143.5	0 - 300
-------	---	------	-----	-----	-----	-------	---------

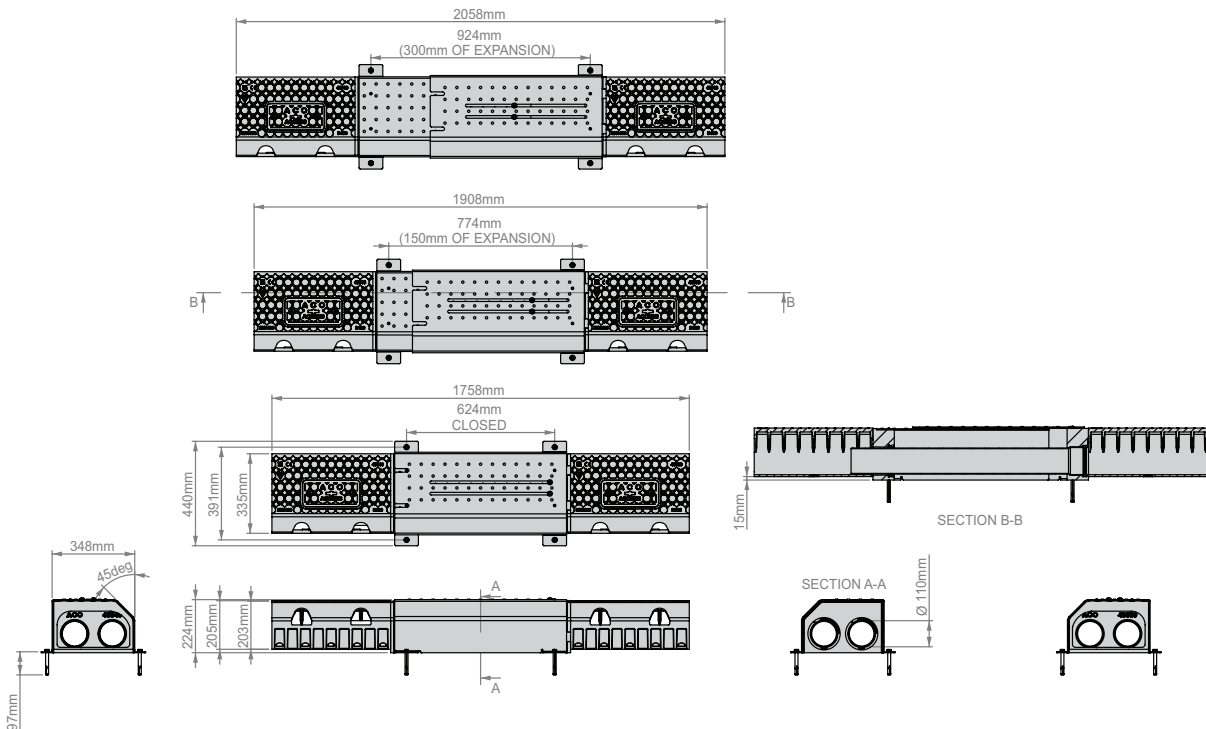

# Splayed expansion joint installation detail

## Load class

Installation recommendations shown are ACO minimum recommendations for BS EN 1433:2002 load class requirements.

## Ground conditions

The long term performance of a channel installation to sustain vertical and lateral loads depends upon A) bridge deck conditions B) stability of the adjacent pavement and C) a durable mortar bed.

## Cutting and jointing

Mitre joints are formed by cutting the channels to the required angle and butting them together with appropriate sealant (e.g. Sikaflex 11FC Purform or similar). For further details please contact ACO Design Services Team. Avoid cutting through the inlet aperture, we recommend any cuts should be a minimum of 25mm away.

## Block pavements

Blocks or slabs bedded on sand remote from the channel should be set at a higher level to compensate for possible settlement of the paving in service.

## Installation upstand heights

The dimension (X), as shown within the detail, shows different upstand heights for each profile. This would be governed by the kerb upstand required for the highway. The channels should always be installed with a kerb face height of between 100mm and 125mm for Half Battered and between 75mm and 100mm for Splay KerbDrain BridgeDeck.

## Joint lubrication

Prior to installation the joint should be lubricated using a white lithium grease. Once installed, additional lubrication should be applied as part of a regular maintenance regime. Grease can be applied through the use of the Access Unit or in the slots of the expansion joint cover.

## Setting out

As shown within the detail, the location of the BridgeDeck Expansion Joint fixing anchors should take into account site ambient temperature and the likely expansion and contraction of the joint to be encountered following installation. They should also avoid the Bridge Expansion Joint fixings.

## Watertight installation to BS EN 1433:2002

Where ACO channel joints/fittings and channel/pavement interfaces are to be sealed, an appropriate sealant should be used (e.g. Sikaflex 11FC Purform or similar). Guidance on the necessary surface preparation and/or priming should be sought from the sealant manufacturer.

For guidance a typical method of application follows:

- The end faces of the channels are to be sound and free from dust, oil, and grease, with any loose material or dirt removed, e.g. by mechanical wire brush. No water drops should be evident.
- Using a standard cartridge gun, apply the sealant evenly and with no flaws. The detail on the ends of a channel varies from one product to another.
- Products with a basically flat face - apply the sealant in a layer approximately 5mm thick to one face of the joint.
- Products with a sealing groove within the end face - apply the sealant in a bead of approximately 10mm diameter into the sealing groove.
- Products with a sealing groove following the inside shape of the channel - apply the sealant to the end face of the channel and to the sealant groove, such that when the joint is completed, the sealant will both cover the end face and fill the groove.
- The channel unit should be placed on the prepared concrete or mortar bedding and pressed against the previously placed channel unit. A sealed joint of approximately 1-2mm width should be formed between adjacent channel units.
- Excess sealant should be wiped from the inside face of the channel to leave a smooth finish.
- The sealant is to be left to cure for 24 hours, during which time the sealant should be kept as dry as possible.



The ACO BridgeDeck expansion joint cover and end caps can be set out by measuring the bridge expansion gap on the day of installation. The difference between the joint at 0% expansion and the measurement taken on the day (+10%) will be the amount the cover is opened by. Take the cover in the measured open position and place this equidistant about the bridge expansion joint.

Sequence of Works:

- Set out bolt locations.
- Drill holes and insert anchor bolts with sleeve. Waterproofing seal to be introduced.
- Lay 25mm mortar below fixing flanges and end plates. Ensure mortar bed does not exceed flanges for fixing holes.
- Lay assembled unit onto anchors and mortar.
- Tighten anchor bolts.
- Lay access units on 50mm mortar bed with sealant at joints.

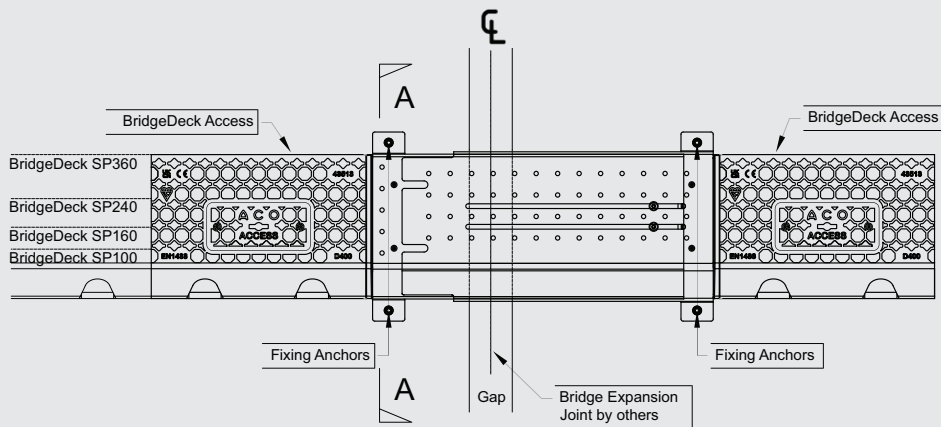

(X: BridgeDeck upstand to suit application - See Note 6.0)

Plan View

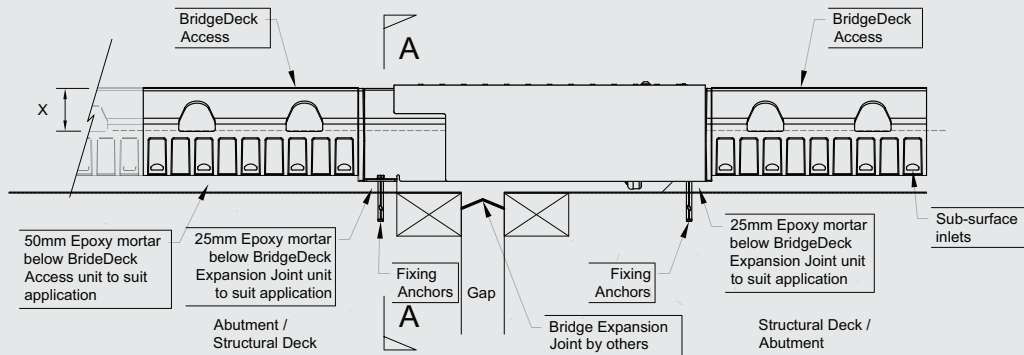

Front Elevation

Moulded Expansion Joint (section view)

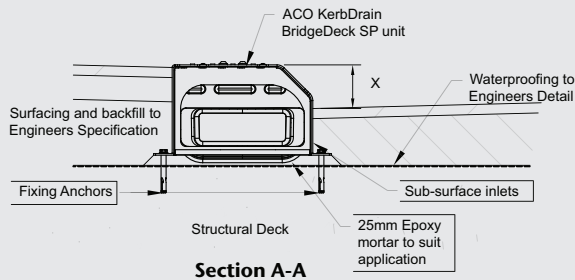

Section A-A

Polymer Expansion Joint (section view)

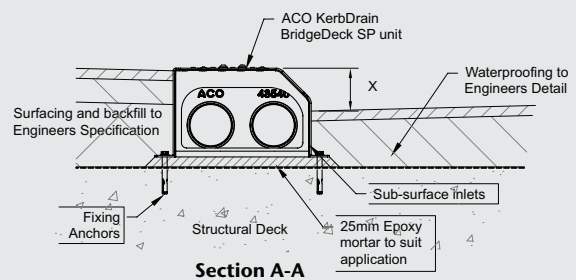

Section A-A

# Outlet connectors



Product Code	Description	Length [mm]	Width Overall [mm]	Depth [mm]	Invert Depth [mm]	Weight [kg]
<b>ACO KerbDrain® BridgeDeck outlet connectors (ductile iron - black)</b>						
43524	Ø110mm KerbDrain BridgeDeck outlet connector	150	150	66	N/A	1.31
43523	Ø160mm KerbDrain BridgeDeck outlet connector	200	200	88	N/A	2.25

Ø110mm KerbDrain BridgeDeck outlet connector

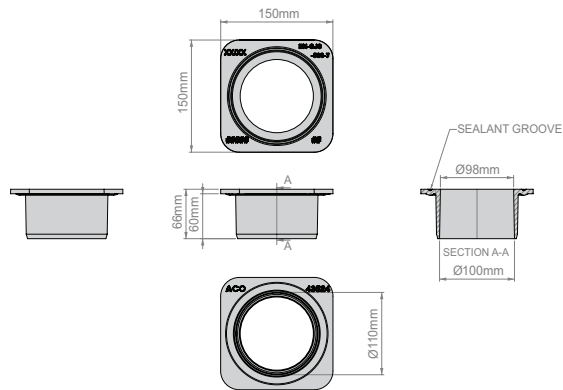

Ø160mm KerbDrain BridgeDeck outlet connector

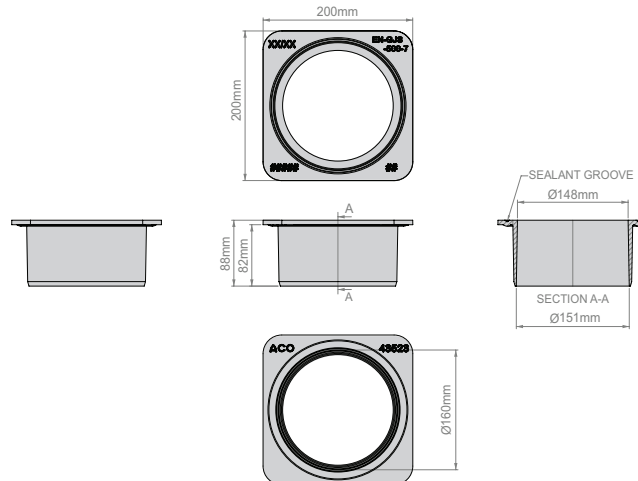

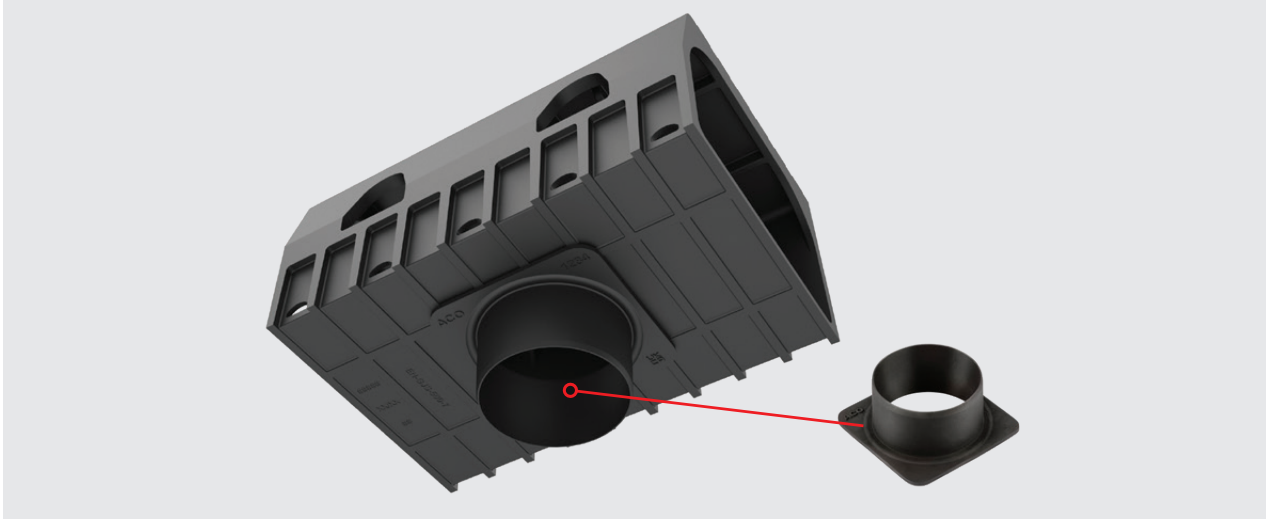

## Outlet connector fitting instructions:



**1** Make sure you have the correct tools and PPE required to carry out the task.



**2** Locate the required outlet location on the base of the channel to match the size of outlet connector you would like to connect (110mm or 160mm).



**3** Using an angle grinder with a 1mm disc attached, cut through the base of the channel separating it into four segments (see example above).



**4** Angling the angle grinder, work on the outer perimeter of one of the four segments, do this by rolling the disc around the edge to weaken the segment.



**5** Once you have weakened one of the segments, take a hammer and hit that segment to break it away.

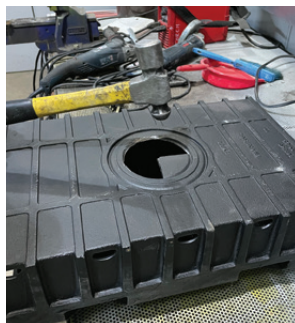

**6** For the 3 remaining segments, you can just break these off with a blow from a hammer.



**7** Once the outlet has been cut away, place a bead of our recommended sealants, such as Sikaflex 11FC or Geocel 945 into the sealant groove on the outlet connector.



**8** Position the outlet connector over the outlet hole and place down firmly to ensure the sealant bead bonds the 2 together.

For further information regarding fitting the outlet connector please contact our Design Services Team at [technical@aco.co.uk](mailto:technical@aco.co.uk)

# Multifunctional end caps



Product Code	Description	Length [mm]	Width Overall [mm]	Depth [mm]	Invert Depth [mm]	Weight [kg]
43536	KerbDrain BridgeDeck HB Multifunctional end cap	40	335	226	N/A	5.61
43535	KerbDrain BridgeDeck SP Multifunctional end cap	40	335	203	N/A	4.97

KerbDrain BridgeDeck HB end cap

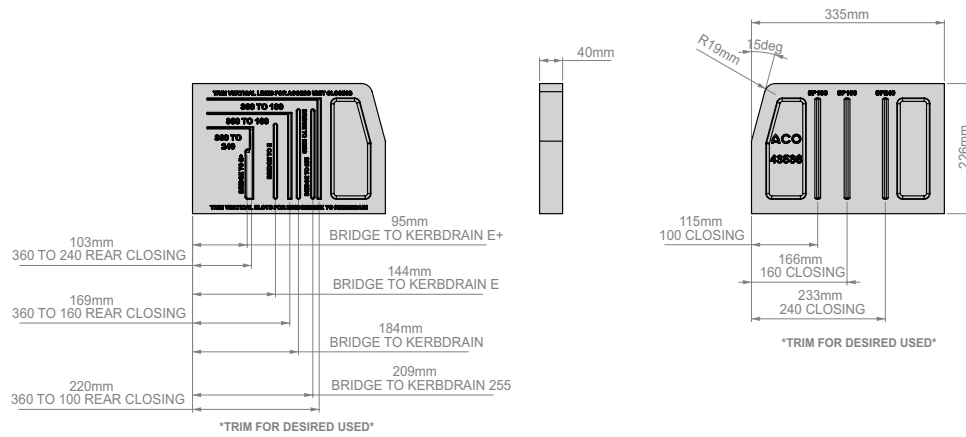

KerbDrain BridgeDeck SP end cap

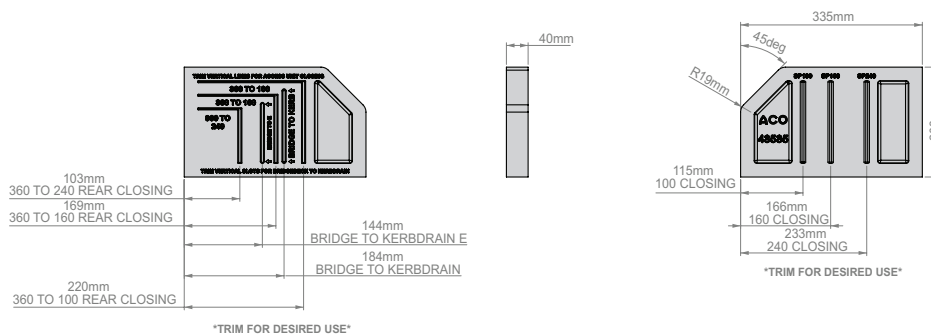

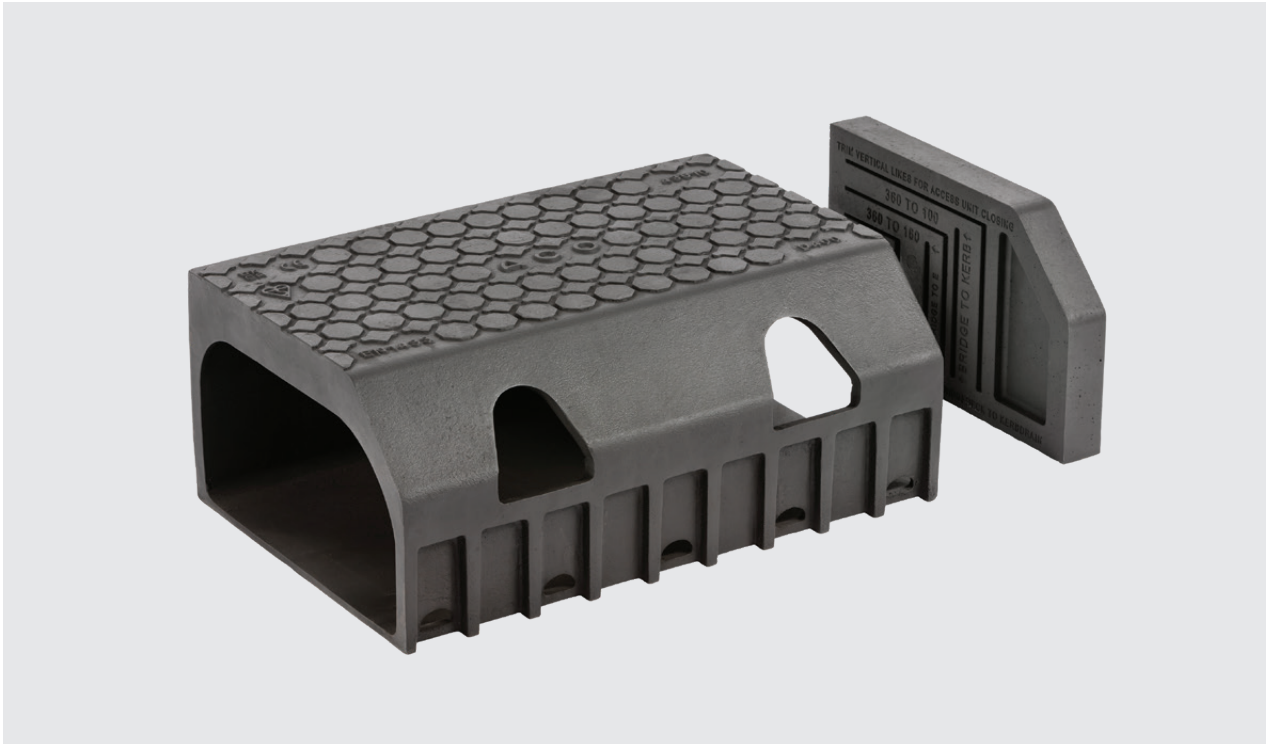

### Multifunctional end cap fitting instructions:



**1** Locate the required cut line on the end cap depending on the application you require. Mark this cut line up with chalk.



**2** Cut the end cap using a disk cutter along the line you marked earlier.



**3** Once cut, install the end cap using a recommended sealant such as Sikaflex 11FC or Geocel 945.



**4** The process is the same whether you are ending a run, transitioning between BridgeDeck units or from BridgeDeck to KerbDrain.

For further information regarding fitting the multifunctional end cap please contact our Design Services Team at [technical@aco.co.uk](mailto:technical@aco.co.uk)

# Maintenance

Regular maintenance of the system is advised, especially where expansion joint solutions are used. Greasing of the rubber seals and male expansion joint end caps is essential every six months, for both expansion joint systems maintenance is expected to take place regularly to assist with the smooth running of the system. Regular jetting and cleaning using the appropriate equipment is expected to allow the system to work as required.

## Polymer expansion joint maintenance



**1** Untighten and then remove the access covers located on the top of the access channels at either end of the expansion joint.



**2** Working on the right-hand access channel facing the road, take your lithium white grease can and spray the PVC pipes located in the access channel through the opening on top of the channel.

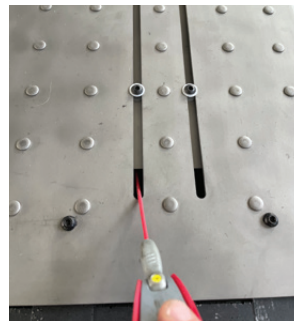

**3** When the slots on the cover are open, you should also spray white lithium grease through these slots onto the top of the PVC below.



**4** Once you have lubricated both of the locations, the access cover should be placed back into position and fixed down.

## Moulded expansion joint maintenance



**1** Untighten and then remove the access covers located on the top of the access channels at either end of the expansion joint.



**2** Working on the right-hand access channel facing the road, take your lithium white grease can and spray down the expansion joint through the opening on top of the channel.

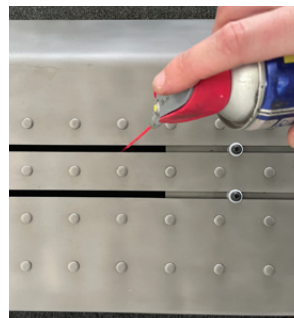

**3** When the slots on the cover are open, you should also spray white lithium grease through these slots onto the top of the moulded expansion joint below.



**4** Once you have lubricated both of the locations, the access cover should be placed back into position and fixed down.

## Associated products and systems

As indicated on previous pages within the brochure, KerbDrain® BridgeDeck is fully compatible with ACO KerbDrain® combined kerb and drainage channel system to allow for a seamless transition from bridge to highway drainage.

It is also compatible with ACO's own range of Stainless Steel Pipe systems, which are available through our sister division in the UK, ACO Building Drainage.

Further details for both options can be found by visiting the relevant webpages:

[www.aco.co.uk/products/kerbdrain](http://www.aco.co.uk/products/kerbdrain)

[www.aco.co.uk/products/aco-pipe](http://www.aco.co.uk/products/aco-pipe)

ACO KerbDrain®



BridgeDeck to KerbDrain Transition

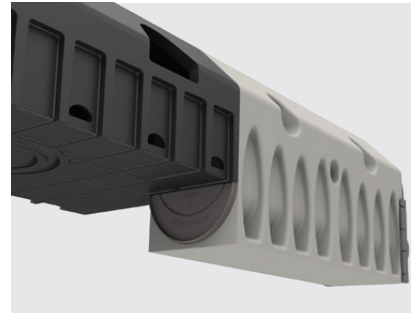
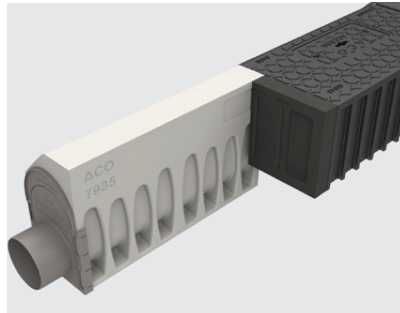

ACO Stainless Steel Pipe

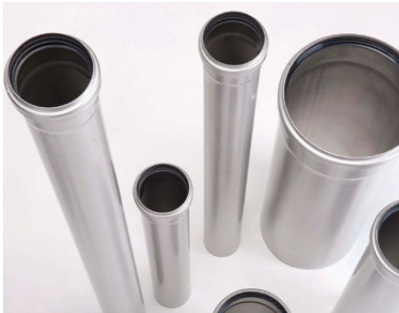

Stainless Steel Pipe Options



## Design support services

Surface water management system design can often be a complex task. Success in combining products and processes requires a thorough understanding of how these different elements work together.

The ACO Design Services Team is able to work closely with you through the entire design process to ensure accurate and cost-effective product selection is made.

Services we offer include (free and without obligation):

- Whole system design, from collection to the attenuation of surface water
- Hydraulic calculations and AutoCAD detailing
- Parts schedules
- Conduit files for MicroDrainage

ACO has embraced the concept of value engineering as an approach to on-site construction that saves both time and money.

ACO will review any design to minimise the total scheme and life cost of a proposal. The team can suggest the most appropriate range depending on your requirements.

Some ranges like MultiDrain or MonoDrain allow water to be contained and conveyed close to the surface, which accords with the principles advocated for Sustainable Drainage (SuDS Manual, 2015), by removing the need for pumping. Other ranges like Qmax allow attenuation – the storage of large volumes of water during storm events, reducing overall site costs.

For detailed designs using the ACO Hydraulic Design Software, please contact the ACO Water Management Design Services Team.

If manual calculations are preferred to using our QUAD software, hydraulic tables and instructions for manual calculations can be provided.

For design enquiries go to [www.aco.co.uk/design-+-support-services](http://www.aco.co.uk/design-+-support-services)







## ACO BIM Models

BIM is the process of generating and managing data, and developing collaborative behaviours that will unlock new and more efficient ways of working at all stages of the project life-cycle.

These files will help contractors specify and optimise drainage systems in line with the overall benefits of BIM-

enabled working, including faster project delivery, reduced costs, reduced waste and greater project predictability.

Civils3D, IFC or Revit files are available for download.

**[www.aco.co.uk/aco-bim-models](http://www.aco.co.uk/aco-bim-models)**

# Further Learning

## ACO Professional Development

ACO has recognised that knowledge transfer is fundamental in keeping up-to-date with the latest advancements in surface water management and has a unique training offer that can be accessed online, in-house or at the state-of-art training facility at the ACO Academy.

### In Company

ACO offers face-to-face professional development sessions. These are carefully designed to last up to 1 hour, so they can be undertaken across a lunch break.



A member of our team will contact you directly to discuss your requirements and will tailor the session to meet your needs.

### ACO Academy Days

ACO's training facility at its UK head office in Bedfordshire has a theatre-style facility that can hold up to 50 people as well as a number of breakout rooms for small groups.



Professional development training can be combined with more in-depth product training at the on-site learning zone.

### Webinars

ACO has developed a series of webinars that will keep you up to date, bringing you technical expertise as well as more specific product information. Whatever your involvement from specification to installation, there will be a webinar to meet your needs and further your learning.



### Seminars

ACO is bringing the experts to you via our programme of regional events, and by sharing information from key influencers within the industry as well as more specific product information. ACO's seminar events will include opportunities to enhance existing knowledge as well as network and discuss thoughts and ideas with other delegates.



[www.aco.co.uk/professional\\_development](http://www.aco.co.uk/professional_development) | email: [ukprofessionaldevelopment@aco.co.uk](mailto:ukprofessionaldevelopment@aco.co.uk)



Case Studies

ACO has operated in the UK for over 30 years and in this time we have worked on ground breaking projects that have pushed the boundaries of surface water management. Our case studies provide bite sized information that counts towards your professional development and can provide inspiration for future projects.

[www.aco.co.uk/case-studies](http://www.aco.co.uk/case-studies)



Colab

Colab is a collaboration of partnerships, bringing together CPD and self-certified content to ensure that knowledge is shared and accessible to the construction industry. Visit our content and CPD partner website: Colab to see more professional development content from partners such as ACO, FutureBuild, CIHT, The Edge, and CIWEM.

[www.colab-cpd.co.uk](http://www.colab-cpd.co.uk)



# askACO

train | design | support | care



Every product from ACO Water Management supports the ACO WaterCycle



- 
- ACO Water Management  
Civils + Infrastructure  
Building + Landscape
  - ACO Building Drainage
  - ACO Access
  - ACO Sport
  - ACO Wildlife
- 

### ACO Water Management

A division of ACO Technologies plc

ACO Business Park  
Hitchin Road  
Shefford  
Bedfordshire  
SG17 5TE

Tel: 01462 816666  
Sales: [customersupport@aco.co.uk](mailto:customersupport@aco.co.uk)  
Project pricing: [awmprojects@aco.co.uk](mailto:awmprojects@aco.co.uk)  
Technical: [technical@aco.co.uk](mailto:technical@aco.co.uk)

[www.aco.co.uk](http://www.aco.co.uk)

ACO. we care for water

